

MICRO™

THE 6502 JOURNAL

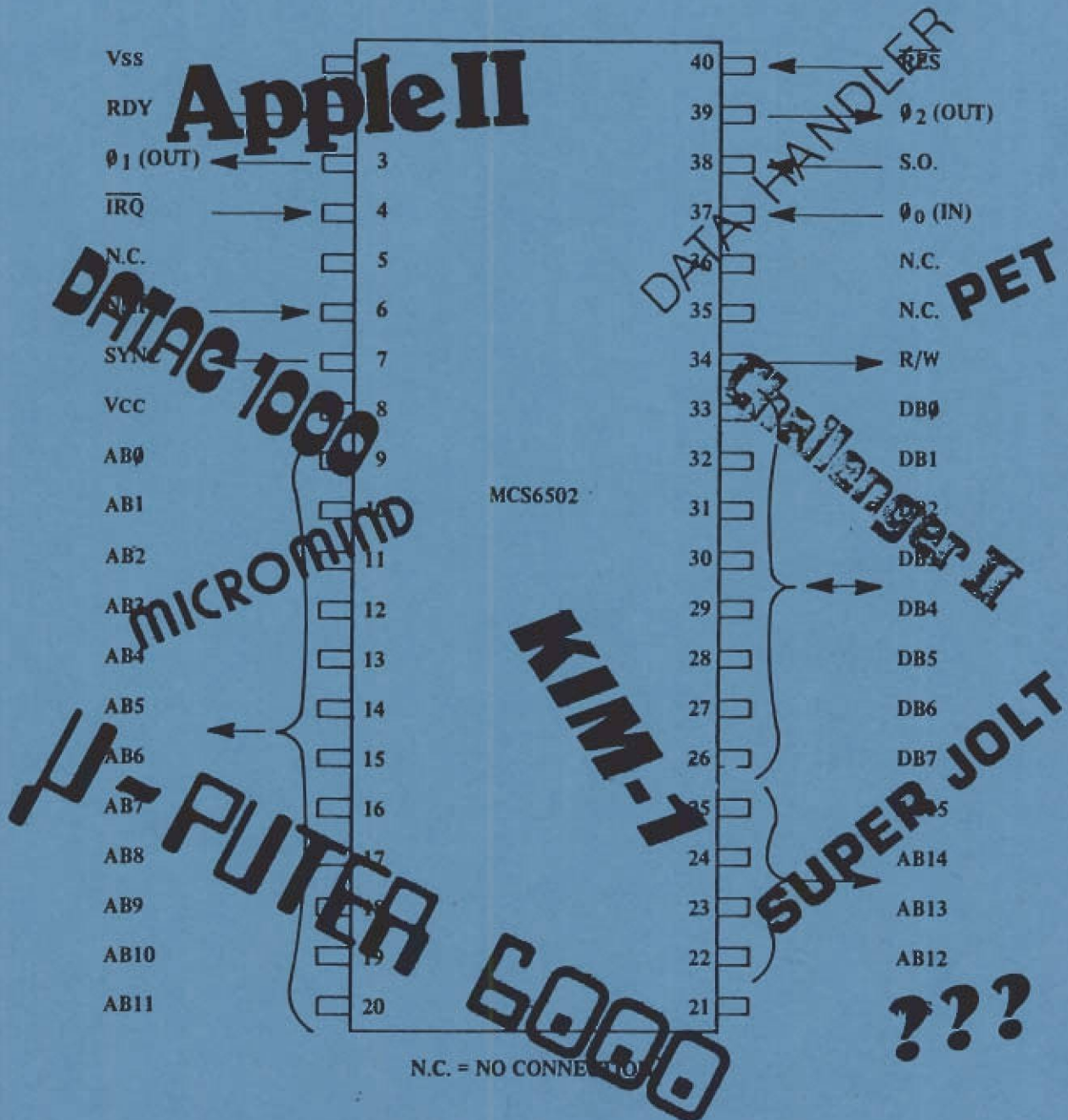

QUICK CHANGE ARTISTRY

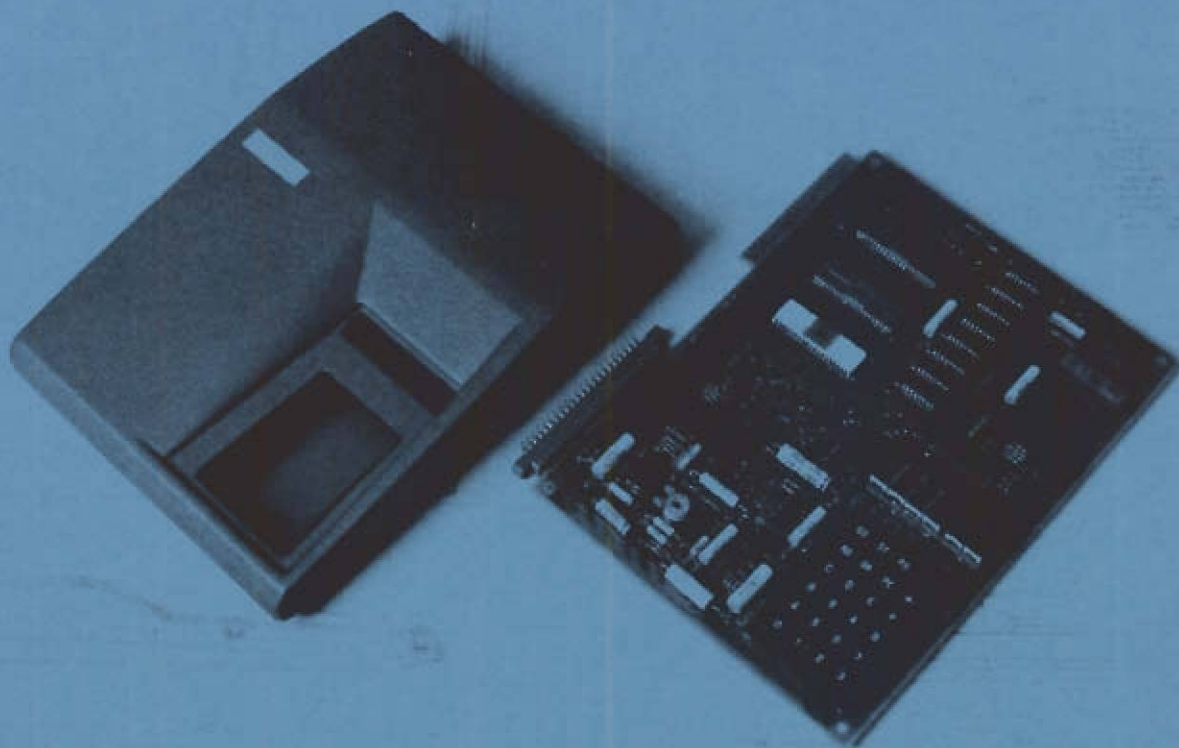

ENGINEERED SPECIFICALLY FOR THE KIM-1 MICRO COMPUTER

- Protection of Chips and Other Components
- Viewing Angle of Readout Enhanced
- Improved Keyboard Position for Easier Operation

EASILY ASSEMBLED

- Absolutely No Alteration of KIM-1 Required
- All Fasteners Provided
- Goes Together in Minutes with a Small Screwdriver

ATTRACTIVE FUNCTIONAL PACKAGE

- Professional Appearance
- Four Color Combinations
- Improves Man/Machine Interface

MADE OF HIGH IMPACT STRENGTH THERMOFORMED PLASTIC

- Kydex 100[®]
- Durable
- Molded-In Color
- Non-Conductive

AVAILABLE FROM STOCK

- Allow Two to Three Weeks for Processing and Delivery
- No COD's Please
- Dealer Inquiries Invited

TO ORDER: 1. Fill in this Coupon (Print or Type Please)
2. Attach Check or Money Order and Mail to:

NAME _____

STREET _____

CITY _____

STATE _____ ZIP _____

Please Ship Prepaid _____ SKE 1-1(s)
@ \$23.50 Each

California Residents please pay
\$25.03 (Includes Sales Tax)

**the
enclosures
group**

55 stevenson, san francisco 94105

Color Desired blue beige
black white

MICRO

FEBRUARY/MARCH 1973

ISSUE NUMBER THREE

Employing the KIM-1 Microcomputer as a Timer and Data Logging Module by Marvin L. DeJong	3
Machine Language Used in "Ludwig von Apple II" by C.R. (Chuck) Carpenter W5USJ	8
The PEI Vet Tackles Data Files by Charles Floto	9
Hold That Data by Gary L. Tater	11
The MICRO Software Catalog - A Call for Information	12
Printing with the Apple II by C.R. (Chuck) Carpenter W5USJ	13
Typesetting on a 6502 System by Robert M. Tripp	19
TIM Meets the S100 Bus by Gary L. Tater	25
The Apple II Power Supply Revisited by Rod Holt	28
MICROBES - Tiny Bugs in Previous MICROS	28
A Simple Frequency Counter Using the KIM-1 by Charles R. Husbands	29
6502 Bibliography - Part II by William Dial	33
Lighting the KIM-1 Display by Marvin L. DeJong	back cover

Advertisers Index

The Enclosures Group	IFC	K L Power Supplies	18
Computer Shop	1	CGRS Microtech	27
Pyramid Data Systems	12	A B Computers	27
Computer Playground	17	Forethought Products	27
Riverside Electronic Design Inc.	18	The COMPUTERIST	IBC

MICRO is published bi-monthly by The COMPUTERIST, 8 Fourth Lane, So. Chelmsford, MA 01824. Robert M. Tripp Editor/Publisher. Controlled circulation postage paid at Chelmsford, Massachusetts.

Subscription Rate: \$6.00 per year (six issues) in U.S.A.

Copyright 1973 by The COMPUTERIST. All Rights Reserved.

COMPUTER SHOP

288 NORFOLK ST. CAMBRIDGE, MASS. 02139
 corner of Hampshire & Norfolk St. 617-661-2670

NOW WE HAVE OSI AND YOU CAN GET ONTO THE BUS

You can now adapt you KIM to the OSI Motherboard easily because it has buffers built into the Board. Application notes are available. You cant beat the \$39.00 price for an 8 slot motherboard. Once you get onto their motherboard you can get their 4K memory board assembled for \$125.00, or their 16 K board for \$596.00 assembled. We can supply you with all the other goodies as well such as: Video Graphics, Prom and parallel I/O, cassette and Analog I/O. Or you can switch to their complete Challenger II P for \$598.00. It has an 8K ROM Basic , Video 32x64 Cassette,, and a real keyboard. Order Now!

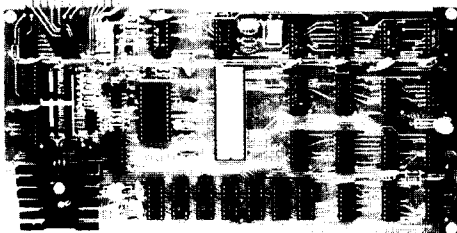
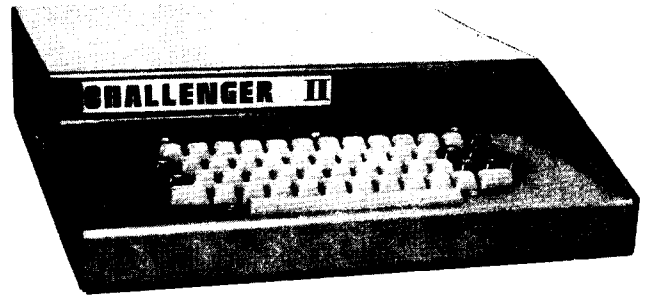

The CS100 VIDEO TERMINAL BOARD IS A 16 LINE BY 64 CHARACTER DISPLAY GENERATOR WITH CURSOR CONTROL AND EDITING Connect a 5V. ASCII Keyboard to it, a Regulated 5 Volt, Unregulat-8 Volts, or 8 Volts AC, and your KIM Teletype port to it along with a video monitor and away you go with all the convenience of a Video Terminal on your KIM.



- C2-0 Board assmb. Serial I/O ROM Basic 298.00
- C2-1 above with Cabinet & Pwr Supp. 429.00
- C2-4P Challenger II P Kbd & Video..... 598.00
- CM- 1 4K 1MHz. Memory..... 125.00
- CM-2 4K 2MHz. Memory..... 149.00
- CM-3 16K 1.5 MHz. Ultra Low Pwr. Mem... 596.00
- CA-7 I/O Board..... 399.00
- 480 Backplane..Motherboard..... 39.00
- all above are OSI products available from us.
- VF8 4K Memory assembled & tested. 129.00
- for low power RAM add..... 10.00
- same in kit form..... 74.50
- full set of sockets for Kit..... 10.00
- VF8 Motherboard buffered for 4 Boards..... 65.00
- Connector Assembly for KIM to VF8..... 20.00
- 8K S100 Memory Board with instructions.K 165.00
- same but fully assembled and tested ... 199.00
- CS100 Cabinet cut out for KIM..... 129.00
- 3 Connector S100 Motherboard Assembly..... 75.00
- CGRS S100 TIM Kit..... 129.00
- CGRS S100 6502 CPU Kit..... 179.00
- CGRS S100 Front Panel Kit..... 129.00
- XITEX Video Terminal Board 16X64K..... 155.00
- XITEX Video Terminal Board Assembled... 185.00
- KIM-1..... 245.00
- CS100 with CGRS, Xitex, 16KRAM, TV, KB 1529.00
- Same but Assembled..... 1989.00
- PS-5 Pwr Supp. 5V5A9V1A-12V1A6x6X2..... 75.00
- PS-5 Assembled..... 90.00
- Total of Order.. Circle Items wanted. \$.....
- Mass. Residents Sales Tax 5%..... \$.....
- Shipping, 1%(\$2.00 min.)..... \$.....
- Total Remittance or Charge..... \$.....

BAC, VISA, MC NO.

SIGNATURE.....

NAME.....

ADDRESS.....

CITY..... STATE..... ZIP.....

EMPLOYING THE KIM-1 MICROCOMPUTER AS A TIMER AND DATA LOGGING MODULE

Marvin L. De Jong
Dept. of Mathematics-Physics
The School of the Ozarks
Point Lookout, MO 65726

The interval timers on the 6530 on the KIM-1 microcomputer provide a convenient way to measure the time between two or more events. Such events might include the start and end of a race, the exit of a bullet from a gun and its arrival at a measured distance along its trajectory, the interruption of light to a series of phototransistors placed along the path of a falling object, an animal arriving at this feeding station, the arrival of telephone calls, etc. Some of these measurements will be described in more detail below. Each event must produce a negative pulse which the microcomputer detects and records the time at which the event occurred. The time is stored in memory and later displayed on the 6-digit KIM display.

Description of the Programs

The data logging, timer, and display programs are listed in Tables 1, 2, and 3, respectively. The programs must be used together for the applications described in this paper, but each might be used with other applications, for example pulse generators, frequency counters, temperature logging, light flashing, etc. The events to be timed must produce either a one-shot pulse (positive-zero-positive) whose duration is at least 50 microseconds or a zero to positive transition which must be reset to zero before the next event. These signals are applied to pin PA0 on the KIM applications connector. The programs could easily be modified to detect positive pulses.

The first pulse starts the timer which continues to operate on an interrupt basis. The first pulse is not recorded by the data logging program since it corresponds to $t = 0$. Successive pulses cause the data logging program to store the six digit time counter in memory. The number of events (not counting the first event) N , to be timed must be stored in location 0003.

Remember to convert the number of events, N , to base 16 before entering it in memory. As the program is written, N must be less than 75. = 4B hex.

The function of the timer program is to load the interval timer, increment the six digit time counter, and return to the data logging program. At the end of each timing period the timer causes an interrupt to occur (pin PB7 on the application connector must be connected to pin 4 on the expansion connector), the computer jumps to the timer program, does its thing, and returns to the main data logging program to wait for events.

Table 4 lists several timing intervals which are possible and the numbers which must be loaded into the various timers to produce the given interval. For example, if one wishes to measure time in units of 100 microseconds, then 49 hex must be stored in the divide-by-one counter whose address is 170C. In this case, the numbers which appear on the display during the display portion of the program represent the number of 100 microsecond intervals between the first event and the event whose time is being displayed. To put it another way, multiply the number on the display by 0.0001 to get the time in seconds. The other possibilities listed in the table are treated in the same way.

When all N events have been logged, the program automatically jumps to the display program. When one is ready to record the data, key #1 on the keyboard is depressed. The time of each event, excepting the first which occurred at $t = 0$ is displayed on the six digit read-out for several seconds before the display moves to the time of the next event. This gives the experimenter time to record the data on paper. If more time is required, increase the value of the number stored in location 0289.

Table 4 also lists the measured time interval and gives the percent error between the stated interval (say 100 microseconds) and the actual measured interval (99.98 microseconds). The measurements were made by connecting a frequency counter (PASCO SCIENTIFIC Model 8015) to pin PB7 while the program was running and after the first event had started the timer. If greater accuracy is required for the 10 millisecond and 100 millisecond intervals, then experiment with putting NOP instructions between the PHA instruction and the LDA TIME instruction in the timer program.

Experiments and Applications

The simplest application for the program is a simple stopwatch with memory. Any suitably debounced switch can be used. See pages 213 and 280 in CMOS COOKBOOK by Don Lancaster, published by Howard W. Sams & Co., Inc., 4300 West 62nd St., Indianapolis, Indiana 46268 for some suitable switching circuits.

Being a physics teacher, I originally designed the program to collect data for an "acceleration of gravity" experiment in the introductory physics lab. The technique may be applicable to other problems so it is described herein. Nine phototransistors (Fairchild FPT 100 available from Radio Shack) were mounted on a meter stick at 10 cm intervals. An incandescent (do not try fluorescent lighting) 150 watt flood lamp provided the illumination. The interface circuit is shown in Figure 1.

The 555 timer serves as a Schmitt trigger and buffer which produces a negative pulse when an object passes between the light and the phototransistor. The 500 kilo ohm potentiometer is adjusted so that an interruption of the light to any of the phototransistors increases the voltage at pin 2 of the 555 from about 1.5 volts to at least 3.5 volts; a very simple adjustment which should be made with a VTVM or other high impedance meter.

In the case of a simple pendulum, the relationship between the period and the amplitude can be investigated by allowing the pendulum to "run down" while logging the times when the bob interrupts the light to a single phototransistor. With only one phototransistor

the timer-data logging program can also be used as a tachometer if a rotating system of some kind is involved.

Lancaster, in the CMOS COOKBOOK, describes a tracking photocell pickoff which could be used in conjunction with the program for outdoor races and other sporting events. See page 346 in the "COOKBOOK". A simple light beam-photo-transistor system could be placed in a cage and the apparatus would record the times at which an animal interrupted the beam, giving a measurement of animal activity.

If you want to measure the muzzle velocity of your rifle or handgun, you will have to be more devious. First, I would modify the program so that one pin, say PA0, is used to start the timing while another pin, say PB0, is used to stop the timing. This can be accomplished by changing instructions 0226 and 022D in Table 1 from AD 00 17 to AD 02 17. Then I would use a fine wire foil to hold the clock input of a 7474 flip-flop low until the wire foil was broken by the exit of the bullet from the gun. The Q output going high would start the timing, so it would be connected to PA0. To end the timing one could use a microphone to detect a bullet hitting the backstop. Of course, the microphone signal would have to be amplified and used to trigger say the other flip-flop of the 7474 to signal the second event. So as not to take all your fun away, that is the last hint except that the distance between start and stop should be at least 10 feet. Please be careful.

I would like to acknowledge the education and inspiration I received at an NSF Chautauqua Type Short Course and a KIM workshop, both conducted by Dr. Robert Tinker.

[Editor's Note: For a related KIM-1 application, see "A Simple Frequency Counter Using the KIM-1", by Charles R. Husbands, on page 29 of this issue.]

DLOG	ORG	\$0200
LOW	*	\$0000
MID	*	\$0001
HIGH	*	\$0002
N	*	\$0003
LO	*	\$0003
MI	*	\$0053
HI	*	\$00A3
INH	*	\$00F9
POINTL	*	\$00FA
POINTH	*	\$00FB
KEY	*	\$0271
PAD	*	\$1700
GETKEY	*	\$1F6A
SCANDS	*	\$1F1F

Table 1
Data logging program

0200	78	INIT	SEI	DISABLE INTERRUPT
0201	F8		SED	SET DECIMAL MODE
0202	A2 00		LDXIM \$00	SET X = 0
0204	A9 50		LDAIM \$50	SET INTERRUPT VECTOR = 0250
0206	8D FE 17		STA \$17FE	
0209	A9 02		LDAIM \$02	
020B	8D FF 17		STA \$17FF	
020E	A9 FF		LDAIM \$FF	INIT COUNTER BY STORING 255 (FF)
0210	85 00		STAZ LOW	INT THE THREE, TWO DIGIT
0212	85 01		STAZ MID	MEMORY LOCATIONS OF THE
0214	85 02		STAZ HIGH	COUNTER
0216	AD 00 17	START	LDA PAD	READ INPUT PIN PA0
0219	29 01		ANDIM \$01	LOGICAL AND WITH PA0
021B	D0 F9		BNE START	LOOP IF PIN IS 1
021D	AD 00 17	FLIP	LDA PAD	IF PIN IS NOT 1, READ AGAIN
0220	29 01		ANDIM \$01	LOGICAL AND WITH PA0
0222	F0 F9		BEQ FLIP	LOOP IF PIN IS 0
0224	58		CLI	ELSE, ENABLE INTERRUPT AND JUMP TO
0225	00		BRK	TIMER PROGRAM THEN RETURN
0226	EA		NOP	PADDING FOR BRK COMMAND
0227	AD 00 17	CHEK1	LDA PAD	THESE INSTRUCTIONS ARE THE SAME
022A	29 01		ANDIM \$01	AS THE START AND FLIP SEQUENCE
022C	D0 F9		BNE CHEK1	
022E	AD 00 17	CHEK2	LDA PAD	
0231	29 01		ANDIM \$01	
0233	F0 F9		BEQ CHEK2	
0235	E8		INX	INCREMENT X FOR EACH DATA POINT
0236	A5 00		LDAZ LOW	COUNTER CONTENTS ARE STORED IN A
0238	95 03		STAZX LO	SEQUENCE OF LOCATIONS INDEXED
023A	A5 01		LDAZ MID	BY X
023C	95 53		STAZX MI	
023E	A5 02		LDAZ HIGH	
0240	95 A3		STAZX HI	
0242	E4 03		CPXZ N	COMPARE X TO N. RETURN TO CHEK1
0244	D0 E1		BNE CHEK1	IF X IS LESS THAN N
0246	78	DISPLA	SEI	ELSE GO TO DISPLAY AFTER
0247	4C 71 02		JMP KEY	DISABLING INTERRUPTS

TIMER	ORG	\$0250
TIME	*	\$0049
TIMEX	*	\$170C
LOW	*	\$0000
MID	*	\$0001
HIGH	*	\$0002

Table 2
Timer program

0250	48	INTRPT	PHA	PUSH ACCUMULATOR ON STACK	
0251	A9	49	LDAIM	TIME	START TIMER FOR 49(16) CYCLES
0253	8D	OC	17	STA	TIMEX
0256	A9	01	LDAIM	\$01	INCREMENT COUNTER BY ADDINT 1
0258	65	00	ADCZ	LOW	TO THE TWO LOW DIGITS
025A	85	00	STAZ	LOW	AND STOR RESULT
025C	A9	00	LDAIM	\$00	ADD CARRY FROM PREVIOUS
025E	65	01	ADCZ	MID	ADDITION TO MID DIGITS. IF
0260	85	01	STAZ	MID	CARRY OCCURS FROM THE TWO MID
0262	A9	00	LDAIM	\$00	FROM THE TWO MID DIGITS, THEN
0264	65	02	ADCZ	HIGH	ADD THIS TO THE TO HIGH DIGITS
0266	85	02	STAZ	HIGH	
0268	68		PLA		PULL ACCUMULATOR FROM STACK
0269	40		RTI		RETURN TO DATA LOGGER

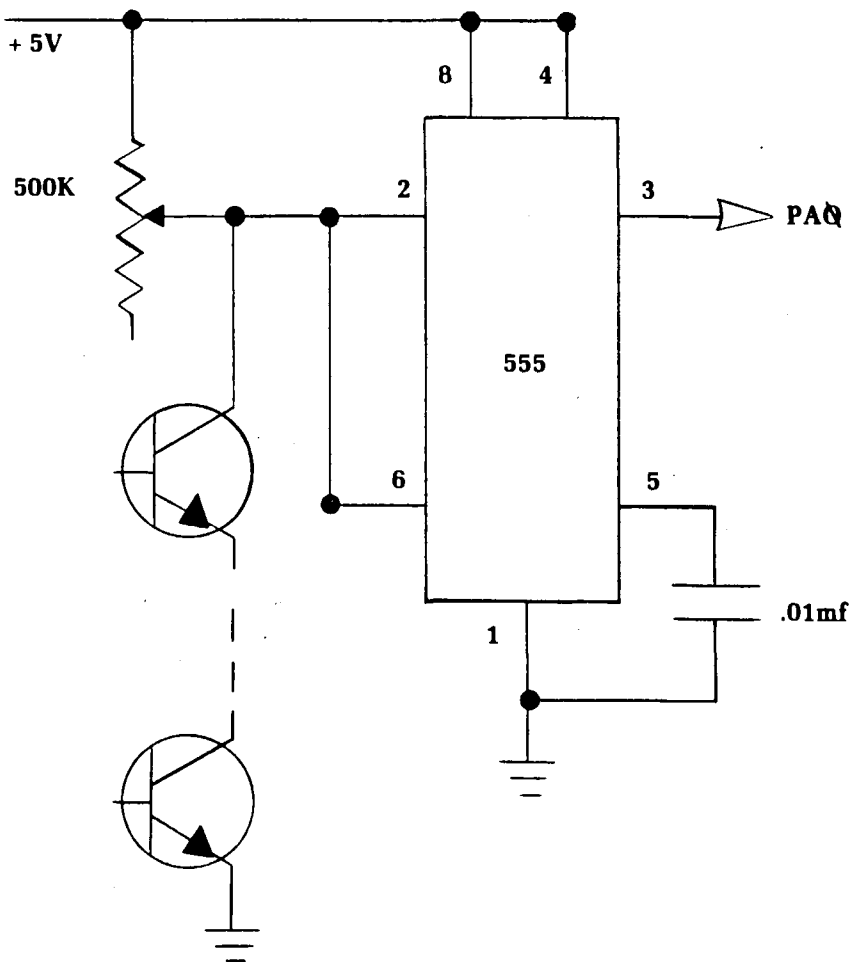

Figure 1

Interface circuit using up to 10 phototransistors. The dashed line represents other phototransistors. The time at which the light to any of the phototransistors is interrupted is recorded by the timer-data logging program.

```

DISPLA  ORG  $0271

N      *    $0003
LO     *    $0003
MI     *    $0053
HI     *    $00A3
INH    *    $00F9
POINTL *    $00FA
POINTH *    $00FB
INIT   *    $0200
TIME   *    $1707
GETKEY *    $1F6A
SCANDS *    $1F1F

```

Table 3
Display program

```

0271 20 6A 1F KEY JSR GETKEY JUMP TO KIM KEYBOARD MONITOR
0274 C9 01      CMPIM $01 TEST VALID INPUT
0276 D0 F9      BNE KEY IF NOT, WAIT FOR INPUT
0278 A2 01      LDXIM $01 INIT X REGISTER TO INDEX
027A B5 03      NXPNT LDAZX LO DATA POINTS
027C 85 F9      STAZ INH PUN IN KIM DISPLAY REGISTERS
027E B5 53      LDAZX MI
0280 85 FA      STAZ POINTL
0282 B5 A3      LDAZX HI
0284 85 FB      STAZ POINTH
0286 8A        TXA SAVE X WHILE IN SUBROUTINE BY
0287 48        PHA PUSHING IT ON THE STACK
0288 A0 10      LDYIM $10 TIME TO DISPLAY EACH POINT
028A 98        AGN TYA SAVE Y WHILE IN SUBROUTINE BY
028B 48        PHA PUSHING IT ON THE STACK
028C A9 FF      LDAIM $FF
028E 8D 07 17   STA TIME
0291 20 1F 1F REPEAT JSR SCANDS SCANDS IS KIM ROUTINE WHICH
0294 AD 07 17   LDA TIME DISPLAYS DATA IN 00F9, 00FA
0297 30 03      BMI OVER AND 00FB. REPEATED JUMPS TO
0299 4C 91 02   JMP REPEAT SCANDS PRODUCES A CONSTANT DISPLAY
029C 68        OVER PLA RESTORE Y REGISTER
029D A8        TAY
029E 88        DEY DECREMENT Y BY 1 AND REPEAT
029F F0 03      BEQ HOP DISPLAY UNTIL Y = 0
02A1 4C 8A 02   JMP AGN
02A4 68        HOP PLA RESTORE X REGISTER
02A5 AA        TAX
02A6 E0 03      CPXIM N COMPARE X WITH N. IF X IS LESS
02A8 F0 04      BEQ BEGIN THAN N INCREMENT X AND DISPLAY
02AA E8        INX NEXT POINT. ELSE, RETURN TO
02AB 4C 7A 02   JMP NXPNT THE BEGINNING
02AE 4C 00 02   BEGIN JMP INIT

```

Table 4	Time Interval	Value	Address	Measured Interval	% Error
Timing intervals for the program.	100 microsec	49	170C	99.98 microsec	0.02%
	1 millisecc	7A	170D	0.9998 millisecc	0.02%
	10 millisecc	9C	170E	10.007 millisecc	0.07%
	100 millisecc	62	170F	100.5 millisecc	0.5%

MACHINE LANGUAGE USED IN "LUDWIG VON APPLE II"

C. R. (Chuck) Carpenter W5USJ
2228 Montclair Place
Carrollton, TX 75006

As an Apple II owner, I found the article "Ludwig von Apple II" (by Marc Schwartz, MICRO #2, page 19) quite interesting. The machine language routine used by Marc is put into the BASIC program by use of the POKE statement and I was curious to see the type of program used to activate the Apple II on-board speaker. To do this, I converted the decimal values used for the POKE statements into HEX with my TI Programmer. Then I loaded the values into the computer using the system monitor commands that are part of the Apple II functions.

Once I had the program loaded, I used the monitor commands to list an assembled version of the routine, as shown in Figure 1. The assembler provides a listing of the program and the mnemonics used with the machine language opcodes. This made it easier to determine what was happening in Marc's program. At this point I wanted to see what would happen if I ran the program by itself - as a machine language routine only.

```

0000- 0F      ???
0001- 00      BRK
0002- A0 30 C0  LDA  $C030
0005- A5 00      LDA  $00
0007- 20 A8 FC  JSR  $FCA8
000A- A5 01      LDA  $01
000C- D0 04      BNE  $0012
000E- C6 18      DEC  $18
0010- F0 05      BEQ  $0017
0012- C6 01      DEC  $01
0014- 4C 02 00  JMP  $0002
0017- 60      RTS
0018- 00      BRK
0019- 00      BRK
001A- 05 4B      ORA  $4B
001C- B6 00      LDX  $00,Y
001E- 0F      ???
001F- 00      PHP
0020- 00      BRK
0021- 00      PLP

```

Figure 1

Because it is somewhat easier to call the routine from a BASIC routine, I entered the BASIC routine shown in Figure 2. This way I could also change the values stored in memory location \$0000 by using the POKE statement. To initialize the beginning of the routine, I entered a value of \$05 into location \$0000. According to Marc, this would produce a high frequency output tone and this turned out to be the case.

Now that I had everything set up, I was curious to see why the duration of playing time is not the same for the different tones. To start with, I entered the program with 3 different values at location \$0000. As I ran the program I timed the length of playing with a stop watch. The value of 5 played for .18 min., 10 played for .45 min. and 15 played for .85 min. This was in agreement with Marc's findings. As it turns out, the length of time a particular frequency plays is a function of the duration of a cycle. The output continues for a number of cycles and the shorter cycles (higher frequencies) get done sooner. To get the correct musical timing you would need to include variable delay time for each note played. (The time between zero crossings adds up to the same total time per note.)

```

>LIST
  10 POKE 0,5
  99 END
>CALL 2
>10 POKE 0,10
>RUN
>CALL 2
>10 POKE 0,15
>RUN
>CALL 2

```

Figure 2

THE PET VET TACKLES DATA FILES

Charles Floto
267 Willow Street
New Haven, CT 06511

Several people have contacted the PET Vet about their difficulties in recording data files on tape and reading the information back in. Preliminary information on PET BASIC lists the commands to be used, but doesn't tell how to put them together. This makes for a frustrating situation, especially as file handling should be one of the PET's strong points.

The following program is offered as a starting point for development according to your specific application. Reading and writing have been combined in one program for two reasons. First, modifications to one process may call for corresponding changes in the other. Second, this minimizes the need to juggle two cassettes while saving programs on one and data on the other. I recommend that a separate cassette be used for data storage. If you use this program please save it on tape before you try to run it. I have found that while I'm experimenting with data files, the PET is especially liable to go out of control, forcing me to turn off the power. The same memory location that controls the tape drive apparently controls a function essential to BASIC.

To write a data file load this program, have a blank cassette in the tape drive and type RUN. Line 50 clears the screen. Lines 60-300 build a string consisting of: a file name or record number followed by two asterisks; data to be saved that may be broken into data fields by delimiters of your choice; and three consecutive backslashes that mark the end of the record. Lines 90 and 100 cause the keyboard to be read until a key is struck. Then 105 echoes it to the screen and 110 adds it to the string. Use of GET rather than INPUT allows the data file to contain commas and carriage returns. Line 190 warns when C\$ is approaching the maximum size; you may wish to have a later or less frequent warning. At

the end of the record type three backslashes. These will be detected in line 300, causing 320 to be executed rather than going back to 90 for another character.

Lines 320-400 write C\$ onto the tape. You will be instructed (on the screen) to press play and record on the tape drive if you have not already done so. In line 320 the first two numbers indicate that device #1 is tape drive 1. The third 1 indicates a write operation. Compare this to line 1000 where the 0 indicates a read command.

Line 450 provides for creation of the next record in the file. To create the last record simply input the record number and type three backslashes. Then, after it has been written, BREAK IN 500 will appear on the screen.

At this point you're ready to rewind the tape and type RUN 900. Lines 910 to 990 initialize 256 empty strings. Lines 1000-1090 read the tape and build up C\$ until three consecutive backslashes are found. Line 2000 prints what has been read while 2850 displays available memory. Then in 3000-3020 C\$ is broken down into its individual elements. These can be manipulated further by adding your own lines between 3050 and 9000. Line 9000 will head back to read the next record unless 3050 has detected the last record in a file.

To record numeric data generated in a program rather than entered from the keyboard it must be converted to a string with the STR\$ function. Then when it's read back the VAL function can be used on data fields representing numbers. For example, N=VAL(B\$(8)+B\$(9)+B\$(10)) might be used if you knew the eighth, ninth and tenth elements of C\$ represented a three-digit number. Of course, it usually won't be nearly so simple as that.

```

50 PRINT CHR$(147)
60 PRINT "ENTER FILE NAME OR RECORD #"
70 INPUT C$
80 C$=C$+"**"
90 GET A$
100 IF A$="" THEN 90
105 PRINT A$;
110 C$=C$+A$
190 IF LEN(C$)>200 THEN PRINT 255-LEN(C$); "BYTES AVAILABLE"
300 IF RIGHT$(C$,3)<>"\\\" THEN 90
320 OPEN 1,1,1,"NAILFILE"
350 PRINT#1,C$
400 CLOSE 1
450 IF RIGHT$(C$,5)<>"**\\\" THEN 50
500 STOP
900 DIM B$(255)
910 FOR J=1 TO 255
920 B$(J)="
930 NEXT J
990 C$=""
1000 OPEN 1,1,0,"NAILFILE"
1010 GET#1,A$
1020 C$=C$+A$
1030 IF A$<>"\" THEN SL=0:GOTO 1010
1040 SL=SL+1
1050 IF SL<3 THEN 1010
1090 CLOSE 1
2000 PRINT C$
2850 PRINT FRE(0); "BYTES FREE"
3000 FOR J=1 TO LEN(C$)
3010 B$(J)=MID$(C$,J,1)
3020 NEXT J
3030 PRINT FRE(0); "BYTES FREE"
3050 IF RIGHT$(C$,5)="**\\\" THEN END
9000 GOTO 910

```

If you have any problems with specific applications of your PET, drop me a note, preferably giving a phone number where you can be reached evenings and weekends. I'd also be interested to see any information you've been able to pry out of Commodore or discover on your own.

Charles Floto

The PET Vet

The PET Shop

I have five game programs for the PET. I will trade one-for-one with anyone else for other PET programs. Those wishing to trade should send cassettes to me and I will send mine in return.

The games are:

GUESS
AIR ACE
BRACKETS
COMPU-ART
LUNAR LANDER

Evan H. Foreman
P.O. Drawer F
Mobile, AL 36601

HOLD THAT DATA

Gary L. Tater
7925 Nottingham Way
Ellicott City, MD 21043

Many programs could be enhanced if the user could stop the data on the video terminal by pressing a key. For instance, during a disassembly or a long directory program, it would be handy to be able to stop new data from coming onto the screen so that the existing data could be carefully examined. This note presents a short subroutine for the 6502 microprocessor which senses when the break key on the terminal is depressed and causes the program to loop until the break key is released. The break key, when depressed, holds the RS 232 line to the computer at a constant logic one.

The flow chart for this subroutine is shown in Figure 1. Typically this routine would be used after a line of data is printed on the CRT. The machine language program is relocatable and can be put in ROM. To use the routine, make a subroutine jump (JSR) to the first location: STOPB. As written, the routine functions with TIM. It can be modified to work with the KIM in either terminal or keypad mode. Using the flow chart and program, you should be able to modify the subroutine as necessary to meet your requirements.

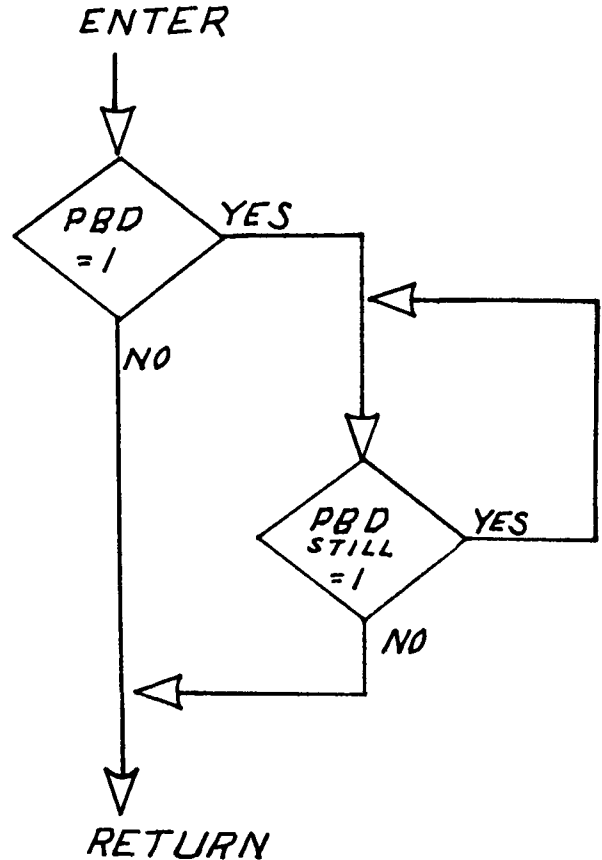

Break Key Test
Subroutine Flow Chart

Figure 1

	ORG	\$0500			
	PBD	*	\$6E02	PORT B FOR TIM	
0500 A9 01 0502 2C 02 6E 0505 D0 01 0507 60	STOPB 	LDAIM \$01 BIT PBD BNE ENDB RTS	\$01 PBD ENDB	SETUP TEST BIT TEST I/O PORT IF 1, BREAK KEY IS ON NOT A BREAK KEY	
0508 2C 02 6E 050B D0 FB 050D 60	ENDB 	BIT PBD BNE ENDB RTS	PBD ENDB	WAIT FOR BREAK KEY TO BE RELEASED THEN RETURN	

Figure 2

THE MICRO SOFTWARE CATALOG

A Call for Information

MICRO would like to present, in the April-May issue, a comprehensive catalog of software currently available for 6502 systems. While we are aware of many of the programs and packages that are on the market, we do not have anything like a complete listing.

If you have 6502 software for sale (or exchange or free), please send us a complete description which includes ALL of the following information:

Name of program:
6502 systems it works on:
Memory locations required:
Language (Assembler, BASIC,...):
Hardware required:
Description of program:
Number of copies sold to date:
Price:
Package contents (Cassette, Source listings, paper tape, ...):
Ordering information:
Company/Author Name and Address:

Please observe the following requirements in submitting your listings:

Programs must be currently available, and at least 25 copies of the program should have been distributed.

Description should be limited to about one hundred words.

All information should be included.

Material must be received by March 20, 1978 in order to be included.

MICRO READERS CAN HELP

Since all authors of 6502 software are not MICRO subscribers, if you have a favorite program you think should be included, send a copy of this call for information to him.

MICRO
P.O. Box 3, S Chelmsford, MA 01824

3:12

MICRO

Kim Stuff

audio cassettes

These 'shorty-cettes' are long enough to store most programs and yet short enough for fast rewind and access. Made with 3M Brand tape. 10 & 20 minute cassettes sold in lots of 5 only-

"**XIM**" \$12.00 ppd. (cassette)
Extended Monitor
adds 17 commands to KIM's
TTY monitor. Four user defined
commands. 45 pg. manual,

2708 E-PROM Programming
\$4.00 plus \$1.00 hndlq.

from your KIM cassette to your
Intel 2708 E-PROM. We supply
HEX dump of programmed E-PROM.

5 - C-10's ... \$3.00 ppd.*
5 - C-20's ... \$3.25 ppd.*

*includes 10 blank cassette style
"stick-on" labels.
sold w/o boxes.

Pyramid Data Systems

6 Terrace Avenue
New Egypt, NJ 08533

PRINTING WITH THE APPLE II

C. R. (Chuck) Carpenter W5USJ
2228 Montclair Place
Carrollton, TX 75006

Hardcopy output from your Apple II is a practical reality. All you need is a TELPAR thermal printer, a simple one-transistor adapter circuit and a machine language printing routine. The printing routine slows the data rate down to 110 (or 300) baud and directs the data stream to ANO (the game paddle connector - annunciator output, port zero). I have the TELPAR PS-40-3C (now PS-48) connected to my Apple II and I am printing everything from Bio-rhythms to Manpower Planning programs. Here are the details for hooking up the printer.

The TELPAR PS-40-3C

The PS-40 (Photo 1) is a 48 column thermal printer using 5.5 inch width paper. The model I have is a 3 chip F8 controlled unit. The current, more compact models use a single chip F8/3870. Inputs are provided for serial TTL, RS 232 and 20 MA current loop. You can also connect a parallel port to the printer and software controllable options are available. The printer can be used as the only I/O if a keyboard is connected as the parallel source. The paper is not too expensive at \$3.00 per 164 foot roll.

Power supply voltages are critical and several are required. (This is the only shortcoming I found with this general purpose printer.) Good regulation is a must from your power supply. Especially the printhead supply voltage (16). Excessive positive deviations here can blow the printhead. Telpar can supply a switching type power supply that will do the job. The connections to the 56 pin edge connector are shown in Figure 1. The connector actually has numbers and letters to designate pins. Somewhere along the line, numbers were assigned to both sides. Be sure you transpose the numbers correctly and connect it to the circuit board properly. Telpar has good repair service, but it still takes time.

Interface Adapter

All that is needed to connect the Apple II to an RS 232 printer input is the adapter circuit shown in Figure 2 (from an Apple application note). I built this circuit on a 16 pin IC header and plugged it in. There is some inconvenience if you want to use the game paddles too, but I think there is a way around this if you choose to do some rewiring.

You can get the -12 volts for this circuit from the main power connector. A short lead and a small connector pin will work. If the pin is small enough, it will slide down inside the -12 volt terminal on the power connector. There are other places like the keyboard where -12 volts is also available. Use caution making this connection.

Making it Print

Now the only part left is a way to get the data slowed down and directed to the ANO output port. Apple has taken care of this detail with the routine shown in Figure 3. You can key in this routine and save it on tape. Each time you have a printing task the program is easily loaded using Apple's system monitor commands. I've used it with machine language programs and both forms of BASIC: Apple's Integer BASIC and Applesoft Floating Point 8K BASIC. The routine is called as follows:

\$380G and RETURN in machine language

CALL 896 in Apple Integer BASIC

X=USR(896) in Applesoft 8K BASIC

Note: A line number is not needed to call the print routine. (380 hex = 896 decimal).

Using RESET will stop the print routine in machine language and in Apple Integer BASIC (return to BASIC with the soft entry CONTROL-C). With Applesoft

in RAM, exiting via RESET and re-entry the soft way with OG works sometimes but usually causes a glitch in BASIC and messes up the program. I avoid this problem by waiting to do any printing until the last thing. Any further changes are made at the slower speed. I would speculate that things like this will clear up when Applesoft is in ROM. I'm still looking for a way to get out of the print routine directly from the BASIC program.

The Tale is Told

As I indicated at the beginning, I'm printing most anything I want to. The 5.5 inch paper width presents some limitations but most programs can be formatted to work okay. There are several features and details I've alluded to but an article to do them justice would take several issues of MICRO to cover.

Telpar has a technical paper that describes them and would be happy to send you one. For a simple, effective, general purpose printer, I have not found a better choice than my Telpar thermal. I think you would find it a good choice too.

For more info, write to:

Telpar Inc.
4132 Billy Mitchell Road
P.O. Box 796
Addison, TX 75001

[Editor's Note: One problem I have found with this thermal printer is that the print is light blue. This can cause great difficulty if you want to copy the output since most xerox-type copiers and many plate-making films are "blind" to light blue.]



Photo 1 (by Jim Chamberlain)

APPLE II and TELPAR Thermal Printer

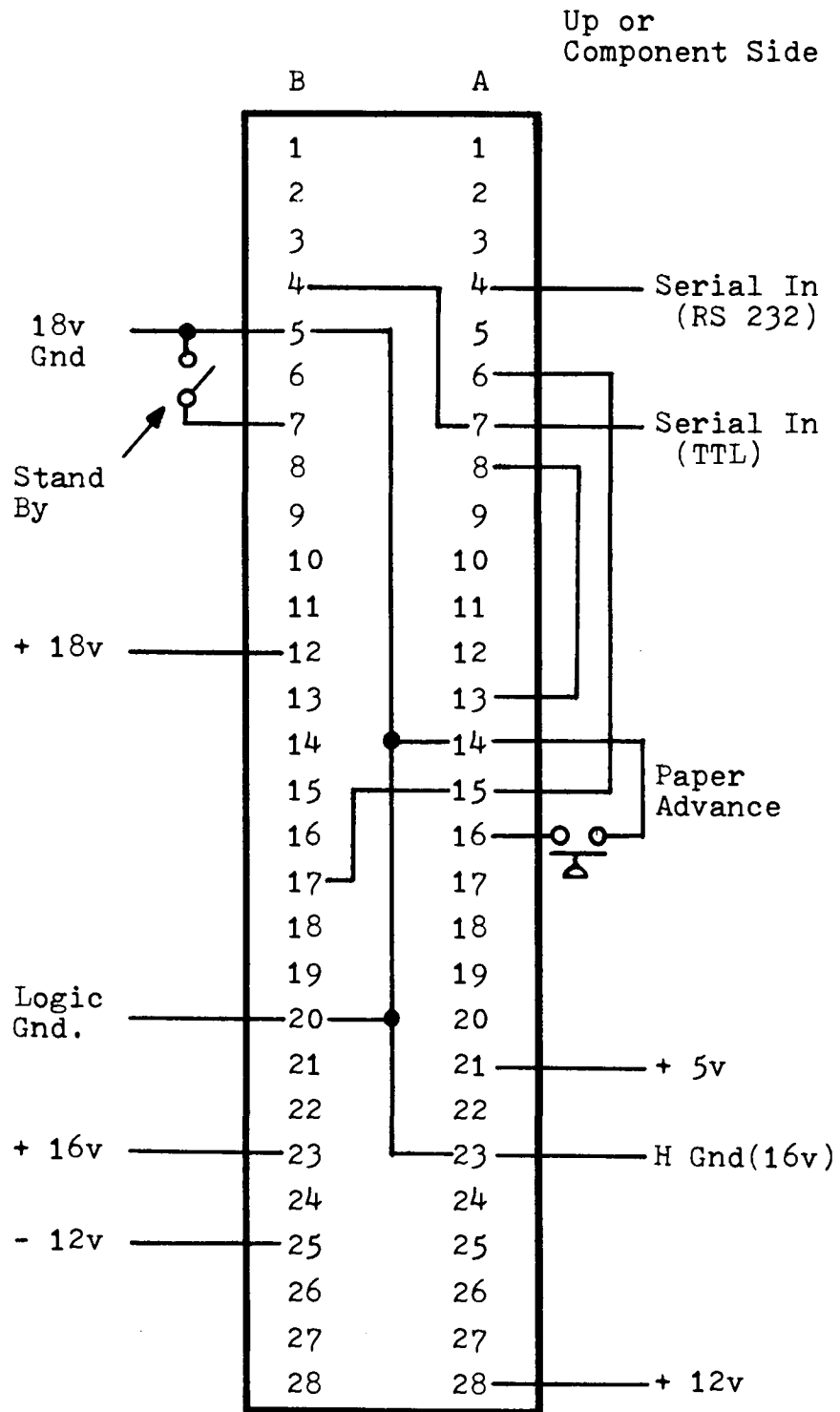

Figure 1

PS-40 Connector Diagram:
Input and Power Connections

*\$B0LLL

```

0380-  A9 89      LDA    ##89
0382-  85 86      STA    #86
0384-  A9 89      LIA    ##89
0386-  85 87      STA    #87
0388-  86      RTS
0389-  84 85      STY    #85
038B-  48      PHA
0390-  80 A5 83   JSR    #03A5
039F-  88      PLA
039D-  09 8D      CMP    ##8D
039E-  D0 8C      BNE    #03A0
0394-  A9 89      LDA    ##89
0396-  80 A5 83   JSR    #03A5
0395-  A9 58      LDA    ##58
039E-  80 A8 FC   JSR    #FCA8
039E-  A9 8D      LDA    ##8D
03A0-  A4 85      LDY    #35
03A2-  40 F0 FD   JMP    #FDF0
03A5-  A0 8B      LDY    #8B
03A7-  18
03A8-  48      PHA
03A9-  80 85      BCS    #03B0
03AB-  AD 58 00   LDA    #0358
03AE-  90 83      BCC    #03B3
03B0-  AD 59 00   LDA    #0359
03B3-  A9 D3      LDA    ##D3
03B5-  48      PHA
03B6-  A9 80      LDA    ##20
03B8-  4A      LSR
03B9-  90 FD      BCC    #03B8
03BB-  68      PLA
03BC-  E9 81      SBC    ##01
03BE-  D0 F5      BNE    #03B5
03C0-  58      PLA
03C1-  6A      ROR
03C2-  58      DEY
03C3-  D0 E3      BNE    #03A8
03C5-  60      RTS
03C6-  56      BRK
03C7-  80      BRK

```

*

Apple II ANO output routine in machine language to provide serial data output at 110 and 300 baud. Change location \$3B4 to \$4D for 300 baud.

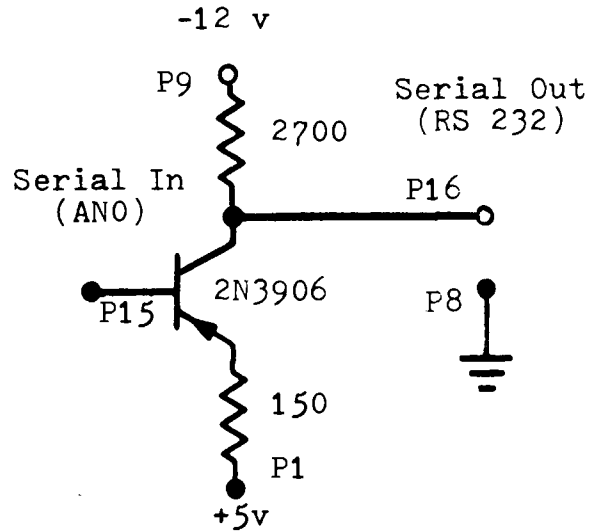

Resistors are in Ohms, 1/2 Watt, 5% P No's refer to game connector pins - P9 and P16 are used as tie points.

Figure 2

Single Transistor Adapter Circuit and Interface

*\$B0.3C7

```

0380-  A9 89 85 86  A9 89 85 87
0388-  80 84 85 48  80 A5 83 83
0390-  09 8D D0 9C  A9 8A 83 A5
0398-  83 A9 58 20  A8 FC A9 8D
03A0-  A4 35 40 F0  FD A0 8B 18
03A8-  48 80 85 AD  58 00 90 83
03B0-  AD 59 00 A9  D3 48 A9 80
03B8-  4A 90 FD 68  E3 81 D0 F5
03C0-  68 6A 88 D0  E3 80 80 80

```

*

[Note: This listing and dump were made on the Telpar printer.]

Figure 3

Machine Language Print Routine and HEX Dump

WE'RE THE APPLE EXPERTS

Check our low prices and large selection of computers, software and peripherals.

APPLE II PERIPHERAL INTERFACE CARDS:

- **S-100 BUS INTERFACE (\$160)[†]**
 - Connect the Apple II to an S-100 Bus Motherboard
 - Will Run Almost All Memory, I/O, and Special Purpose S-100 Boards
 - All Interconnecting Cables and Plugs Supplied (S-100 Motherboard and Power Supply Not Included)
- **PROGRAMMABLE PRINTER INTERFACE (\$80)**
 - Onboard EPROM Printer Driver
 - Full Handshake Logic
 - High Speed Parallel Output Port Capability
 - Provision for 256 Byte I/O Drive in EPROM
 - Printer, Driver Programs Available for Centronic, SWTPC-40, and Other Printers
- **PROTOTYPING BOARD (\$20)**
 - Sixteen Sq. Inches of Development Surface
- **EXTENDER BOARD (\$24)**
 - Completely Contained Inside Apple II
 - Compatible With Prototyping Board
- **FLOPPY DISC SYSTEM (\$1900)**
 - Programs Saved and Loaded by Name
 - Powerful Firmware DOS File Handling Capability
 - 252K Bytes Storage Capacity. 8 Inch Dia. Disc
 - Capable of Utilizing Up to 4 Drives (One Million Bytes)
 - File Handling as Easy as Inputting or Printing
 - Access Methods: Stream, Punctuated, Relative, Direct
- **APPLE POWER CONTROL INTERFACE[†]**
 - Up to Sixteen Control Channels
 - Control Room Lights, Stereo Equipment, Security Systems, Electrical Appliances
 - Handle Up to 1000 Watts per Channel Directly From Program Control
 - Complete Isolation of the Computer From the AC Line
 - PRICE:
 - Apple Power Interface Board and One Power Control Module (\$85)
 - Additional Power Control Modules (Controls Four AC Circuits) (\$25)
 - Appliance Control Module (Controls One AC Circuit) (\$7.50)

[†]Delivery March, 1978

SOFTWARE FOR APPLE II

- | | | | |
|---|-------|---|-------|
| ■ Home Financial Record Program (Req. 16K Sys) | \$ 20 | ■ Word Processor (Req. 20K System) | \$ 50 |
| ■ Business Inventory (Req. 20K Sys) | \$ 40 | ■ High Res. Graphics for F.P. Basic (Req. 24K System) | \$ 30 |
| ■ Bob Bishop's High Resolution Games (Req. 16K Sys) | \$ 40 | ■ High Res. Paddle Drawing Routine | \$ 20 |
| - Star Wars | \$ 15 | ■ Othello Game | \$ 10 |
| - Rocket Lander | \$ 15 | ■ Send for Listing of Our Games, Color Graphics, and Sound Programs | |
| - Saucer Invasion | \$ 15 | | |
| ■ Apple Music (Three Octaves) | \$ 20 | | |
| ■ Data Save to Cassette | \$ 20 | | |

ADD ON MEMORY FOR APPLE II

- Set of Eight 4K RAM CHIPS
- Set of Eight 16K RAM CHIPS

\$ 32
\$320

BOOKS

- 6502 Programming Manual \$ 10
- 6502 Hardware Manual \$ 10

COMPUTER PLAYGROUND
6789 WESTMINSTER AVE.
WESTMINSTER GA. 92683
(714) 898-8330

STORE HOURS:

Tuesday - Friday - 1:00 to 9:00 PM
 Saturday - 10:00 AM to 9:00 PM
 Sunday & Monday - Closed

Mastercharge, Visa, B of A accepted. No C.O.D. Allow two weeks for personal check to clear. Add \$1.50 for handling and postage. For computer system, please add \$10.00 for shipping, handling, and insurance. California residents add 6% sales tax.

MICRO INFORMATION

MICRO is published bi-monthly, six issues per year. Single copy price is \$1.50. Subscriptions are available at the following rates:

Surface Mail: All Countries \$6.00

Air Mail:

Central America	\$12.00
Europe & South America	\$14.00
Other Countries	\$16.00

All subscriptions start with the NEXT issue after receipt of your order.

Back issues are available, while they last, at \$1.50 per copy (plus \$1.25 for air mail postage overseas or \$.50 for surface postage overseas).

Authors will be paid for articles which are printed in MICRO. The payment will be based on the quality of the article, the amount of extra preparation needed to redraw diagrams, etc., as well as type of material. In general, only original material will be considered for publication. There are openings for individuals to contribute on a regular basis: a "KIM Clinic", "Apple Doctor", special interests such as ham radio applications, industrial applications, and so forth.

Advertising in MICRO reaches a lot of people who are seriously interested in the 6502. Advertising deadline for any issue is the 15th of the month prior to publication, e.g. March 15 for the Apr-May issue.

3:18

MICRO

We have the KEM
KIM-1 Expansion Module
the easy way to expand your KIM-1

- * Generates S-100 Bus
- * Accepts 2708 EPROMs
- * ASCII Keyboard port
- * Mates the MVM-1024 Video Module

Write for complete info on the
KEM and MVM-1024 Video Module

**Riverside**
ELECTRONIC DESIGN INC.

1700 NIAGARA STREET
BUFFALO, NEW YORK 14207

Power Supply for KIM \$37

KL Model 512

Total Capacity 4.3 amps
+ 5 volts regulated to 1.4 amp
+ 12 volts regulated to 1.0 amp
+ 8 volts to 4.3 amp
+ 16 volts to 1.0 amp

COMPLETELY ASSEMBLED

Power for KIM-1 and 8K memory
Fused primary
Current limit and thermal overload
protection for regulated outputs
Enclosed in case with rubber feet
Includes line cord and connector cable

DEALER AND QUANTITY PRICES AVAILABLE

KL POWER SUPPLIES

P.O. Box 86
Montgomeryville, PA. 18936

TYPESETTING ON A 6502 SYSTEM

Robert M. Tripp
8 Fourth Lane
S Chelmsford, MA 01824

As Editor/Publisher of MICRO, I was bothered by the need to have typesetting done by an outside company for several reasons. First, of course, was the cost. A typeset page can cost from \$12 to \$30.00. Second, it takes time to have a page set, anywhere from one to five days. Third, once you have the typeset material and are ready to paste up the final copy, it is very difficult to make any changes or corrections. It occurred to me that I should be able to do a reasonable job of typesetting with my existing equipment - a KIM-1 and a Diablo Hytype II based terminal. The results of my efforts are described in this article, and, this entire issue of MICRO has been produced with the equipment and program described.

Actually, "typesetting" is a misnomer for what is being done here. "type" is not being "set". Justification would probably be a better term, but still would not completely cover the features currently implemented. For lack of a term, I named this routine "JUSTIFY".

Features of Justify

JUSTIFY has four modes. The most useful is Full Justification in which a line is set justified at both the left and right margins. The lines you are reading now are an example of a Full Justification. In this mode the width of the column is specified as a parameter to the JUSTIFY routine which then pads the text as necessary to make the text exactly meet the right margin.

The second mode is No Justification. There are a number of instances in which you do not want the material to be justified: the last line of a paragraph, source listings, object listings, any type of tables, and so forth. The following listing makes the point quite graphically:

```
0120 A6 DB      JSTIFY LDXZ CMND
0122 B5 00                LDAZX $00
0124 CA                        DEX
```

which, if set with Full Justification would come out as

```
0120 A6 DB      JSTIFY LDXZ CMND
0122 B5 00                LDAZX $00
0124 CA                        DEX
```

Obviously not what was intended.

The third mode is Center. Title blocks of articles, headers for sections, and so forth need to be centered. The Center mode calculates where to start the text so that it will be properly centered, including splitting a character space in half to get perfect centering.

```
A
AA
AAA
```

The last mode currently implemented is actually not a form of justification, but is useful. It is an enhancement in which characters may be printed slightly bolder than the surrounding text to make them stand out. This mode is independent of the three justification modes and can be combined with any of them.

Although the JUSTIFY routine was made for typesetting MICRO, we have found it has many other uses. Since the editing portion of the program permits you to make corrections before printing, we can type "perfect" letters.

Justification Algorithm

The justification algorithm, or rules, used is based on certain characteristics of the Diablo printer. This printer "thinks small" - it divides the line into units which are 1/120th of an inch. Each printed character is normally 10 units wide, including the space around the character, giving 12

characters per inch. In TEXT mode, there is no way to space the characters other than next to each other as in regular typing, or separated by a full space. If this was the only method of positioning characters, then the justification would consist of expanding the spaces in a line to pick up the extra units to justify a line. This is the method required for a teletype printer. It looks like this:

This is teletype mode justification.

Note that the spaces between words has been doubled in the first three positions. This is not too bad, and as long as there are not too many spaces to distribute, can be acceptable. Given the Diablo's capability of padding with as little as a space of 1/120 of an inch, much better justification be achieved. If there are only a few units to be distributed over the line, then each normal space may be stretched just a little. For example, in a line which is only one character short of full, there are only ten units of space remaining to be distributed, since each character is 10 units wide. If the line contained five normal spaces, then each space would be stretched by two units, an almost imperceptible amount.

Full justification with an extra unit.
Full justification with no extra units.

As the number of units to be distributed increases, there comes a point at which the spaces become noticeably wide. The way this can be solved on the Diablo is to distribute spaces among the characters as well as the spaces. The calculation is done as:

1. Count number of extra units.
2. If there are more units than characters and spaces, then add one or more units to each character and space.
3. If there are fewer units than characters and spaces, then test just the spaces. If there are more units than spaces, then add one or more to each space.
4. When there are finally fewer units than spaces, distribute the remaining units over the first spaces in the line.

Each character has one unit added.
Characters have not had a unit added.

Close inspection will reveal that the first line above has the individual characters spaced slightly wider than the second line. This algorithm will handle most normal lines, but if a line has too many units to fill, it will look strange.

This is a very loose line.

The JUSTIFY Function

JUSTIFY is written in the form of a HELP Function. HELP is a sort of high level language I have developed and is the basis of the Editor, Mailing List, and Information Retrieval packages sold by The COMPUTERIST, as well as a large number of utilities we use internally for such operations as printing labels for cassette tapes, creating copies of program tapes, and so forth. Each of the Functions is, essentially, a subroutine which is called and passed a set of parameters. If the arguments required are placed in the proper locations - OOD9, DA, and DB - and if the instruction at location 01AB is changed from JMP NXTSTP to RTS, then JUSTIFY may be called as a simple subroutine.

Operation of Justify

JSTIFY uses the pointer in CMND+03 to pick up the full address of the buffer which contains the material to be justified, and stores it in BUFFER and BUFFER+01.

CLEAR puts zero in each of the seven counters, NULLS to TEMP, and then puts a zero at the first location past the end of the buffer as defined by the start of the BUFFER and the length as defined by the parameter CMND+01. This zero guarantees a null for the end of buffer test later on.

MORE starts at the end of the buffer to pick up and test each character in order to get a count of the number of nulls, spaces, and other characters. It also tests for a Control N (OE). A Control N is used to signal that No Justification is required on the current line and control branches to NEXT.

JUSTIFY FUNCTION - 16 JAN 1978

JUSTIF ORG \$0120

NULLS * \$00CC
 SPACES * \$00CD
 CHARS * \$00CE
 COFSET * \$00CF
 SOFSET * \$00D0
 EXCESS * \$00D1
 TEMP * \$00D2
 POINT * \$00D3
 BUFFER * \$00D4
 MODE * \$00D6
 CMND * \$00D8
 OUTCH * \$1EA0
 NXTSTP * \$0304

0120 A6 DB	JSTIFY	LDXZ	CMND	+03
0122 B5 00		LDAZX	\$00	
0124 85 D4		STAZ	BUFFER	
0126 B5 01		LDAZX	\$01	
0128 85 D5		STAZ	BUFFER	+01
012A A2 07		LDXIM	\$07	
012C A9 00		LDAIM	\$00	
012E 95 CC	CLEAR	STAZX	NULLS	
0130 CA		DEX		
0131 10 FB		BPL	CLEAR	
0133 A4 D9		LDYZ	CMND	+01
0135 91 D4		STAIY	BUFFER	
0137 88		DEY		
0138 B1 D4	MORE	LDAIY	BUFFER	GET CHARACTER TO COUNT
013A C9 0E		CMPIM	\$0E	
013C F0 59		BEQ	NEXT	NO JUSTIFICATION
013E C9 20		CMPIM	\$20	TEST SPACE CHARACTER OR LESS
0140 F0 1E		BEQ	SCOUNT	EQUAL SPACE
0142 10 1E		BPL	CCOUNT	EQUAL CHARACTER
0144 E6 CC		INCZ	NULLS	EQUAL NULL
0146 88	AGAIN	DEY		DECREMENT STRING COUNTER
0147 10 EF		BPL	MORE	
0149 C8	TEST	INY		
014A B1 D4		LDAIY	BUFFER	
014C C9 0B		CMPIM	\$0B	
014E F0 16		BEQ	CENTER	
0150 C6 CE		DECZ	CHARS	
0152 A6 CC		LDXZ	NULLS	TEST ANY NULLS
0154 F0 41		BEQ	NEXT	NO NULLS
0156 A5 DA		LDAZ	CMND	+02
0158 CA	MULT	DEX		CALCULATE UNITS TO EXPAND
0159 F0 22		BEQ	DIVIDE	GO TO DIVIDE
015B 18		CLC		
015C 65 DA		ADCZ	CMND	+02
015E D0 F8		BNE	MULT	MULT LOOP UNTIL DONE

0160 E6 CD	SCOUNT INCZ	SPACES	
0162 E6 CE	CCOUNT INCZ	CHARS	BUMP SPACES AND CHAR COUNTERS
0164 D0 E0	BNE	AGAIN	
0166 E6 D3	CENTER INCZ	POINT	
0168 46 CC	LSRZ	NULLS	
016A 90 06	BCC	SHIFT	
016C A5 DA	LDAZ	CMND	+02
016E 4A	LSRA		
016F 20 BE 01	JSR	OFFSET	
0172 A9 20	SHIFT LDAIM	\$20	
0174 20 A0 1E	JSR	OUTCH	
0177 C6 CC	DECZ	NULLS	
0179 D0 F7	BNE	SHIFT	
017B F0 1A	BEQ	NEXT	
017D C5 CE	DIVIDE CMPZ	CHARS	TEST CHAR SPACING
017F 30 09	BMI	DIVDON	UNITS < CHARS
0181 38	SEC		UNITS >= CHARS
0182 E5 CE	SBCZ	CHARS	HOW MANY UNITS PER CHAR
0184 E6 CF	INCZ	COFSET	BUMP COUNTERS
0186 E6 D0	INCZ	SOFSET	
0188 D0 F3	BNE	DIVIDE	UNCOND. BRANCH
018A C5 CD	DIVDON CMPZ	SPACES	REMAINDER TO SPACES
018C 30 07	BMI	SDONE	
018E 38	SEC		
018F E5 CD	SBCZ	SPACES	
0191 E6 D0	INCZ	SOFSET	
0193 D0 F5	BNE	DIVDON	
0195 85 D1	SDONE STAZ	EXCESS	REMAINDER TO EXCESS
0197 A4 D3	NEXT LDYZ	POINT	GET STRING POINTER
0199 E6 D3	INCZ	POINT	BUMP FOR NEXT TIME
019B B1 D4	LDAIY	BUFFER	FETCH CHARACTER
019D C9 18	CMPIM	\$18	BOLD?
019F F0 43	BEQ	BOLD	
01A1 C9 19	CMPIM	\$19	NORMAL?
01A3 F0 3F	BEQ	BOLD	
01A5 C9 20	CMPIM	\$20	TEST SPACE
01A7 F0 29	BEQ	SPACE	
01A9 10 03	BPL	CHAR	
01AB 4C 04 03	JMP	NXTSTP	
01AE 20 A0 1E	CHAR JSR	OUTCH	
01B1 C6 CE	DECZ	CHARS	CORRECTION FOR LAST CHAR
01B3 30 E2	BMI	NEXT	LAST CHAR
01B5 A5 CF	LDAZ	COFSET	FETCH OFFSET
01B7 F0 DE	NTEST BEQ	NEXT	
01B9 20 BE 01	JSR	OFFSET	
01BC F0 D9	BEQ	NEXT	
01BE AA	OFFSET TAX		
01BF A9 10	LDAIM	\$10	

01C1	20	A0	1E		JSR	OUTCH
01C4	A9	48		BUMP	LDAIM	'H
01C6	20	A0	1E		JSR	OUTCH
01C9	CA				DEX	
01CA	D0	F8			BNE	BUMP
01CC	A9	1C			LDAIM	\$1C
01CE	20	A0	1E		JSR	OUTCH
01D1	60				RTS	
01D2	20	A0	1E	SPACE	JSR	OUTCH
01D5	A5	D0			LDAZ	SOFSET
01D7	A6	D1			LDXZ	EXCESS
01D9	F0	05			BEQ	NOXCES
01DB	C6	D1			DECZ	EXCESS
01DD	18				CLC	DECREMENT
01DE	69	01			ADCIM	\$01
01E0	C9	00		NOXCES	CMPIM	\$00
01E2	10	D3			BPL	NTEST
01E4	18			BOLD	CLC	
01E5	69	1E			ADCIM	\$1E
01E7	AA				TAX	
01E8	A9	1B			LDAIM	\$1B
01EA	20	A0	1E		JSR	OUTCH
01ED	8A				TXA	
01EE	20	A0	1E		JSR	OUTCH
01F1	D0	A4			BNE	NEXT

TEST first checks to see if the Center Mode has been specified by the Control K (OB) character. It then checks to determine if there are any nulls at the end of the line. If there are no nulls then the line can be printed with no further justification required. It is already justified.

MULT multiplies the number of nulls by the character width provided by parameter CMND+02. This gives the number of units that must be distributed throughout the line to provide left and right justification.

CENTER handles the Center Mode of justification. It bumps over the Control K character and divides the nulls by two so that the nulls will be evenly divided. It tests for an odd or even number of nulls using a BCC after the LSRZ which does the divide. If there are an even number of nulls, then it branches to SHIFT. If there are an odd number of nulls, it picks up the character width from CMND+2, divides this two to get a one-half character offset to provide more accurate centering. This is output via the OFFSET routine.

SHIFT moves the printer to the start of the centered line by outputting spaces equal to one-half the original number of nulls. When finished it branches to NEXT which takes care of printing the text.

DIVIDE allocates the excess units along the line of text to produce the Full Justification. It first tests to see if it can allocate an additional unit to each individual character and space. If so, it increments both the character offset counter (COFSET) and the space offset counter (SOFSET). It then tests whether another unit can be allocated, until it finds that there are fewer units to be allocated than characters and spaces.

DIVDON takes care of any units remaining after the DIVIDE allocation. These are divided among the spaces, incrementing SOFSET until there are fewer units than spaces. The remainder, if any, is stored in EXCESS where it will be used on spaces starting at the beginning of the line.

NEXT handles the printing. It picks up and examines the next character. It branches to BOLD, SPACE, CHAR, or returns to the calling program if a null is encountered.

CHAR outputs the character using the system subroutine, in this case the KIM OUCH subroutine. It tests for last character and puts out the character offset (COFSET) if non-zero.

OFFSET saves the offset in X, then puts the Diablo printer into PLOT mode by outputting a 10 hex. It then puts out one 'H' for each unit of offset, and finally returns the printer to TEXT mode by printing a 1C hex.

SPACE outputs a space, then combines a unit of EXCESS with the space offset and goes to NTEST to output the offset if not zero.

BOLD converts a Control X to '6' or a Control Y to '7', and then outputs the character after issuing an escape 1B hex. This sets or clears the print enhancement mode.

The DIRECT TYPESETTER

One use of JUSTIFY has been in a HELP program for direct typesetting. In this program a sheet of paper is inserted sideways in the terminal. Mate-

rial is entered and edited on the left side of the page and typeset on the right side.

The CPRINT Function outputs a Control Comma (CTLCMA) 1C hex which sets the printer in TEXT mode, and then issues a Carriage Return (CR) 0D hex.

The INPUT Function accepts data from the terminal, places it in the buffer defined by FILE (starts at 1780 and is 39 decimal characters long), and supports some editing features.

The next CPRINT causes the printer to TAB to the right side of the page, to the left margin of the typesetting area.

JUSTIFY does the actual justification and printing. Its parameters specify that the set line has a maximum width of 39 decimal characters; that the width of each character is 10 units; and the 1E is a pointer to the start of the buffer - FFILE.

The last CPRINT sets the printer back one horizontal unit to provide a closer line spacing.

The BRANCH simply returns control to NEXT and the system is ready for the next line to be input.

DIRECT TYPESETTER - 16 Jan 1978

0004	OB1C010D	1	NEXT	CPRINT	CTLCMA	1	CR	TEXT MODE, CARRIAGE RETURN
0008	OB1C0080	2		INPUT	FILE	0	80	CLEAR AND INPUT TEXT
000C	OB090100	3		CPRINT	TAB	1	0	TAB TO TYPESET AREA
0010	01270A1E	4		JUSTIFY	39.	10.	1E	39 CHAR WIDTH, 10 UNITS PER CHAR
0014	OB10014E	5		CPRINT	CTLP	1	"N	PLOT MODE, UP ONE UNIT
0018	03010000	6		BRANCH	NEXT			READY FOR NEXT LINE
001C	20008017	7	FILE	FMAP			FFILE	BUFFER AT 1780
0020	00270000	8	FMAP	00.	39.			FIELD STARTS OFFSET 0, 39. CHAR.

[Editor's Note: Please do not judge the quality of the Diablo Printer by this particular article. This was the last one done, and the printer is sorely in need of adjustment. Look at some of the other articles in this issue to see the quality when the printer is in proper working order.]

TIM MEETS THE S100 BUS

Gary L. Tater
7925 Nottingham Way
Ellicott City, MD 21043

Hardly a computer meeting goes by without a discussion of which bus structure is best. While the S100 bus may not be optimum for the 6502 microprocessor, its use does make purchasing RAM and ROM boards easy.

With this in mind, I purchased a 6502 CPU board for the S100 bus from CGRS Microtech. This CPU board is almost a complete system with its onboard 2K RAM and 4K ROM. But in order to use my CT-64 Southwest Technical Products video terminal with this CPU, I needed an S100 terminal interface monitor (TIM) board. While CGRS markets a very nice TIM board, I elected to build a bare bones S100 TIM board which is described in this article.

In addition to serving as a serial I/O port for a terminal, TIM contains an operating system for 6500 microcomputers. The OCT-NOV issue of MICRO (page 5) contains an article on the operation of the TIM program. In summary, TIM is a read-only memory and I/O device that is self adapting to terminal speeds between 10 - 30 cps. With TIM you can display and alter CPU and memory location using a keyboard and video display; you can read and write hex formatted data from a paper tape or a cassette interface such as the Southwest Technical Products AC-30; and you have an eight bit parallel I/O port where each bit of the eight can be programmed as either input or output.

As you can see from the schematic diagram (Figure 2), only the TIM chip (6530-004) and four integrated circuits are needed; excluding voltage regulators. For the perfectionist, buffering could be added to the address lines, data lines, and parallel output port, but two CGRS Microtech systems are now successfully using this TIM design. Integrated circuits U2 and U3 are used during resets to reconfigure TIM memory locations as described in the previously referenced TIM article. The MC 1488 and MC 1489 are Motorola devices which convert TTL levels to RS 232 levels and RS 232 levels to TTL respectively.

A memory map of this TIM design is provided in Figure 1. For proper operation of a 6502 microprocessor and this TIM board, you will need both page zero and page one memory. Page one is needed by the 6502 microprocessor for its software stack. Page zero memory is used in the TIM program to store the baud rate of your terminal (locations 00EA and 00EB).

To operate a TIM based system you need only momentarily ground pin 16 of TIM (pin #75 of the S100 bus) using a switch on your front panel. After you send a carriage return to the computer, you should see a TIM message such as:

```
7052 30 2E FF 01 FF
```

This message contains first the program counter (7052), processor status register (30), accumulator (2E), X register (FF), Y register (01), and stack pointer (FF). The actual values will vary from machine to machine.

```
7000 - 73FF TIM ROM
FFC0 - FFFF TIM RAM
6E00 - 6E0F TIM I/O
6E02      Serial Port
```

Figure 1
TIM Board Memory Map

If you have a problem, first check all of your wiring and the +5, +12, and -12 voltages. Then insure that your reset switch is controlling pin 16 of TIM. Next, using an oscilloscope, check for a carriage return character at pin 25 of TIM and pin 24 for the TIM message. With a good signal at pin 25 but no answer at pin 24, the last two things to check are the address lines including pin 21, PB4, and finally, check your TIM chip in a working system. The two systems built using this design on prototype boards came up immediately. Hopefully, you will have the same good fortune.

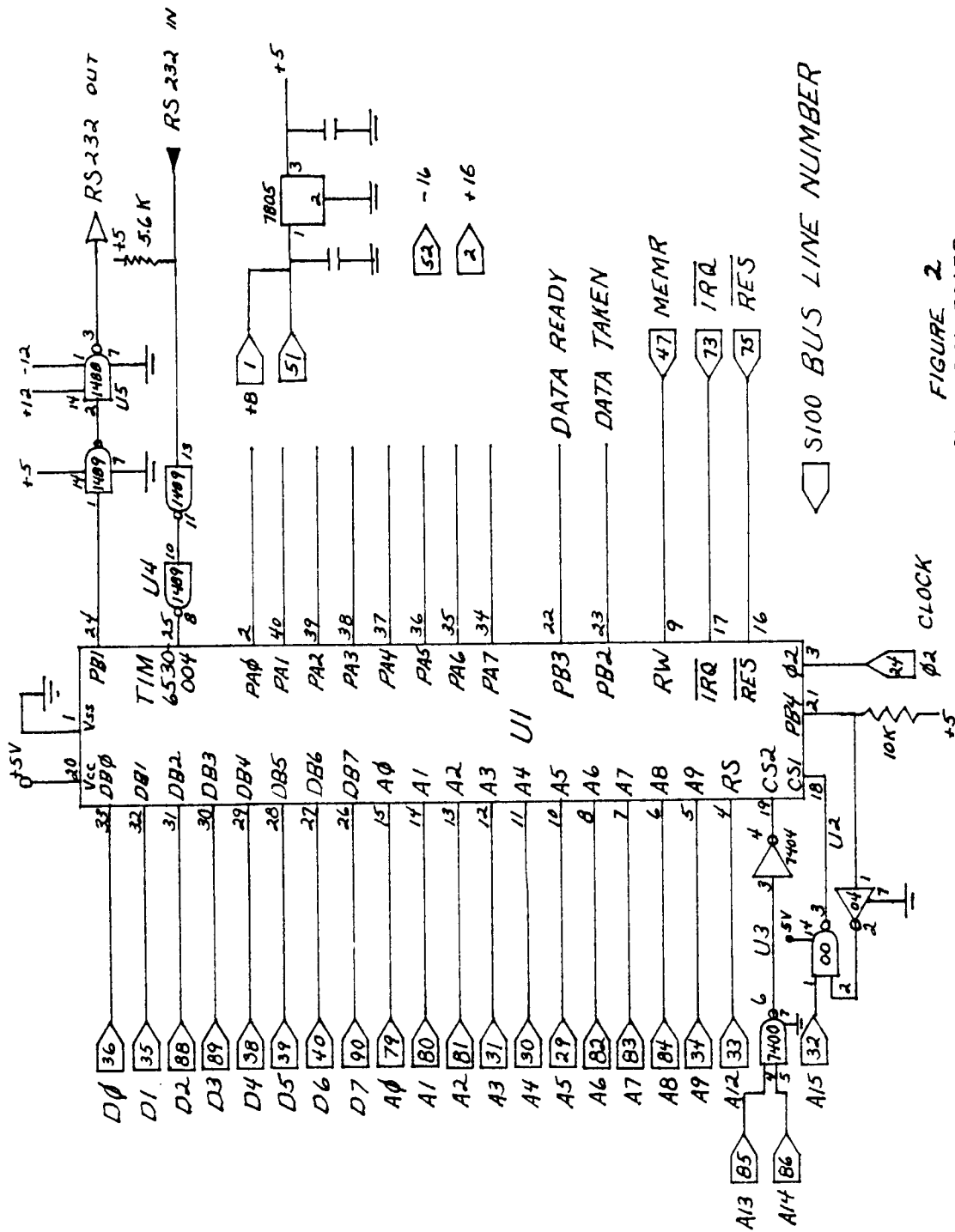

◁ S100 BUS LINE NUMBER

FIGURE 2
S100 TIM BOARD

FINALLY :

6502 ON THE S100

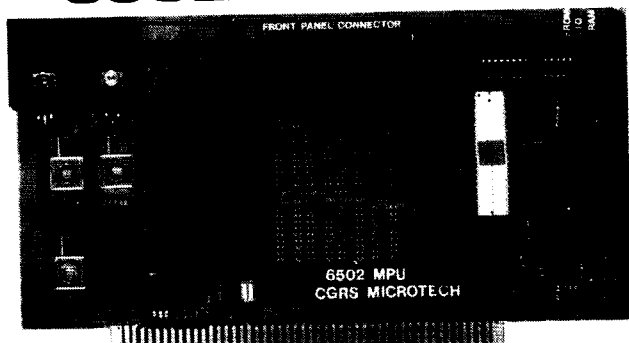

CGRS MICROTECH INTRODUCES A 6502 COMPUTER SYSTEM

- S100 STANDARD BUS COMPATIBLE
- MPU CARD WITH 8K RAM-4K ROM ONBOARD
- T.I.M. (8530) SYSTEM I/O CARD
- D.M.A. FRONT CONTROL PANEL

	KIT	ASSEM
◆ INTRODUCTORY SYSTEM		
MPU CARD: 1K RAM		
FRONT PANEL: HEX DISPLAY	\$249.95	\$299.95
◆ STANDARD SYSTEM		
MPU CARD: 1K RAM		
T.I.M. I/O CARD	\$349.95	\$449.95
S100 MOTHERBOARD: 7 SLOT		
POWER SUPPLY 8V:10A		
±18V:1A		

SEND CHECK OR MONEY ORDER TO:
 CGRS MICROTECH
 P.O. BOX 388
 SOUTHAMPTON, PA 18986

KIM-1 **\$245**

SPECIAL - includes Power Supply

Memory Plus for KIM **\$245**

- 8K low power RAM
- sockets for 8K of 2716 EPROM
- 6522 VIA (includes 2-8 bit ports and 2 timers)
- EPROM programmer
- sockets for all IC's

SPECIAL - includes edge connectors and cable for direct KIM connection

Power Supply for KIM (KL 512) **\$34**

- + 5V, + 12V regulated
- + 8V, + 16V unregulated
- plenty of power for KIM-1 and 8K memory board

First Book of KIM **\$9**

PLEASE games and demo package and cassette **\$15**

MICROCHESS on cassette -- runs in 1K RAM **\$15**

KIM Music System - 4 part harmony **\$35**

ABC Computers

P.O. Box 104, Perkasie, PA. 18944

KIMSI

The KIM to S-100 bus Interface/Motherboard

- Combines the power of the 6502 with the flexibility of the S-100 bus
- Attaches to any unmodified KIM
- Complete interface logic and fully buffered motherboard in one unit
- On-board regulation of power for KIM
- Eight slots of S-100 compatibility for additional RAM. Video and I/O boards, PROM Programmers, Speech processors . . .
- Includes all parts, sockets for ICs, one 100 pin connector, and full Assembly/Operating documentation

◆ Kit \$125, Assembled \$165

◆ All units shipped from stock



FORETHOUGHT PRODUCTS

P.O. Box 386-D
Coburg, OR 97401

(503) 485-8575

Watch for our new
KIM/Kimsi enclosure —
The "Kimsi Case"

THE APPLE II POWER SUPPLY REVISITED

Rod Holt
Chief Engineer
Apple Computer Inc.
20863 Stevens Creek Blvd., B3-C
Cupertino, CA 95014

Your review of the Apple II ("Inside the Apple II" by Arthur Ferruzzi, MICRO #1, Page 9) was most gratifying. However, your comment about the "small" power supply invites a reply.

The power supply has no function other than running the Apple II and its peripherals, and as it does this very well, then what's "small"? Apple Computer is far enough along in peripheral card development to state categorically that with an EPROM card, a ROM card, a parallel printer card, a floppy disk card, and several more all plugged in, the power supply isn't even breathing hard.

We do recommend that users keep their designs to a reasonable minimum power. But the reason for this is the same as one of the reasons Apple designed a switching regulator in the first place: to keep temperature rises to a minimum. The general rule of thumb is that a 25 degree C increase in ambient will drop the mean time between failures by a factor of 10. For the user, the watts saved mean literally thousands of hours more of trouble free system operation. The switcher design cuts the input power nearly in half over conventional regulators and the overall temperature rise is reduced by approximately 25 C.

And, of course, the use of low-power schottky and a tight and economic hardware design is key as well.

A second point needs to be made. It's quite common to have well over a thousand dollars in semiconductors in an Apple II system. The Apple switcher is designed to protect those semiconductors under all fault conditions (including possible failure modes internal to the power supply itself). Never has an Apple II been damaged by its own power supply. In contrast, Apple can document many cases of blown RAM and other IC's where customers have used homemade or "off the shelf" power supplies. See the sad story in EDN, November 20, 1977 page 232. There are many more such sad stories. The power supply manufacturers of the world are just beginning to see that a supply failure means much more than just an equipment shut-down nuisance. Thus it's important to know what happens when, for example, the +12 volt supply is shorted to the -5 volt supply. What happens to the +5 volts? With the Apple switcher, all supplies neatly go to zero, and they all recover smoothly when the short is removed.

I close by murmuring -

"Small is Beautiful".

MICRO

MICROBES - Tiny Bugs in Previous MICROS

1:13 HYPERTAPE and ULTRATAPE

It has been noted that during loading with ULTRATAPE, the KIM Monitor will go back to a normal tape load if the requested Program ID is not located. The normal use of ULTRATAPE is with a group of files with the same ID, so that this does not normally occur. But, it could happen and would really foul things up.

2:7 Making Music with the KIM-1

First two lines of "Score" should be:
0200 60 4A 44 32 24
0205 20 46 40 32 22

2:30 Important Addresses of KIM-1 ...

1EA0 OUTCH Reference was omitted.

A SIMPLE FREQUENCY COUNTER USING THE KIM-1

Charles R. Husbands
24 Blackhorse Drive
Acton, MA 01720

A piece of test equipment that is occasionally very useful in the computer laboratory is a frequency counter. This article explains how to use the capabilities of the KIM-1, with a minimum of additional hardware, to provide the functions of such an instrument. The frequency counter described operates over the audio range from 500 Hz to above 15 KHz. To reduce the amount of external hardware needed, the design assumes TTL level input signals. However, the addition of a small amount of analog hardware to the design presented would allow the counter to be used with analog signal sources.

Basic Counter Mechanization

In order to develop a frequency counter from the KIM-1 microcomputer it is necessary to count and display the number of input pulses detected over a specific time interval. The basic time interval chosen was 100 milliseconds. This time interval is established by using one of the two interval timers available on the KIM-1. Transitions in the applied waveform are sensed by the external logic and force non-maskable interrupts to the KIM. As each interrupt is detected a memory location is incremented. Because of the availability of the decimal mode in the 6502 instruction set, the count can be maintained in decimal rather than binary or hexadecimal form. At the conclusion of the 100 millisecond interval the accumulated count is loaded into the display registers and the process is repeated. Figure 1 is a flow chart of the frequency counter program.

Detailed Software Description

As shown in the flow chart (Figure 1) and in the program listing (Figure 2) the program is started at location 0005 and the frequency counter memory location and display locations are initialized to zero. A Value of 99. is loaded into the interval counter at location 1747. A value stored at this location

is decremented every 1024 microseconds. Under these conditions a zero register value will then be realized 101.376 milliseconds after the register is loaded.

After the initialization process the program goes into an idle loop called DISPLAY and waits for an interrupt to occur. The DISPLAY program consists of repeated calls to the KIM display routine which presents the contents of the display registers 00FA and 00F9 on the seven segment display LEDs.

When an IRQ interrupt is sensed, the KIM logic forces program control to the address stored in memory locations 17FE and 17FF. In this mechanization, the value stored in these locations will direct program control to be transferred to the start of the interrupt routine (location 0021). The interrupt program first stores away the values of A and X from the interrupted program. The contents of the interval timer register, location 1746, is then read to establish if the 100 millisecond interval has been completed. A non zero number indicates that the counter is still counting and an input pulse transition has been detected. The logic sets the processor into the decimal mode and adds one to the contents of the frequency counter location. As we wish to detect values above 1 KHz, a second frequency counter register must be employed to count the overflow from the least significant two decimal digits. Having completed the incrementation process, the program restores the the values of A and X and returns to the interrupted program by executing the RTI instruction.

If a zero value is observed when the interval timer register is read, then the 100 millisecond timing interval has been completed. The program reloads the 100 millisecond value into the interval counter, loads the accumulated count in the frequency counter memory locations into the appropriate display

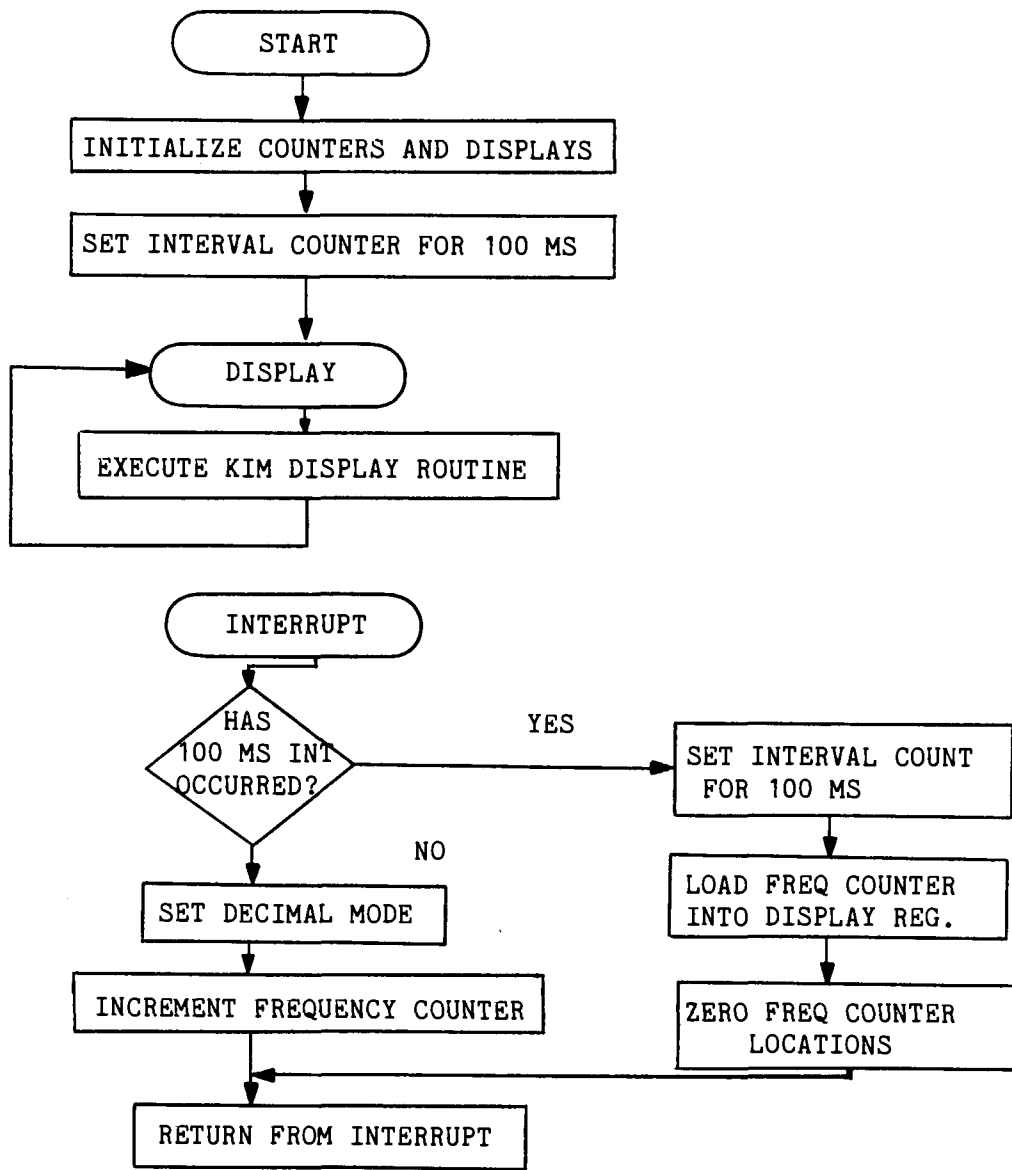

FLOW DIAGRAM FOR FREQUENCY COUNTER PROGRAM

Figure 1

Figure 2

```

                                ORG    $0005

                                INTGER *    $00FA
                                FRACT  *    $00F9
                                PBDD   *    $1703
                                CLOCKX *    $1746
                                CLOCK  *    $1747
                                SCANDS *    $1F1F

0005 A9 00      START  LDAIM $00      INIT COUNTERS AND DISPLAY
0007 85 51          STAZ CNTONE
0009 85 52          STAZ CNTTWO
000B 85 FA          STAZ INTGER
000D 85 F9          STAZ FRACT
000F 8D 03 17      STA  PBDD
0012 A9 62          LDAIM $62      SET UP 100 MILLISECOND TIMER
0014 8D 47 17      STA  CLOCK

0017 20 1F 1F      DISPLA JSR  SCANDS DISPLAY DATA
001A 4C 17 00      JMP  DISPLA CONTINUOUSLY

0021              ORG    $0021

0021 48          INTRPT PHA          SAVE A REGISTER
0022 8A          TXA          SAVE X REGISTER
0023 48          PHA
0024 AD 46 17    LDA  CLOCKX TEST CLOCK TIMED OUT
0027 30 11      BMI  MILLI TEST OF 100 MILLISECONDS

0029 F8          COUNT  SED          SET DECIMAL MODE
002A 18          CLC          CLEAR CARRY BIT
002B A5 51      LDAZ  CNTONE GET FRACTIONAL PART
002D 69 01      ADCIM $01      INCREMENT
002F 85 51      STAZ  CNTONE
0031 A5 52      LDAZ  CNTTWO ADD CARRY BIT IF SET
0033 69 00      ADCIM $00
0035 85 52      STAZ  CNTTWO
0037 4C 4D 00    JMP  EXIT

003A A9 62      MILLI  LDAIM $62      RESET CLOCK
003C 8D 47 17    STA  CLOCK
003F A5 51      LDAZ  CNTONE MOVE DATA TO DISPLAY
0041 85 F9      STAZ  FRACT
0043 A5 52      LDAZ  CNTTWO
0045 85 FA      STAZ  INTGER
0047 A9 00      LDAIM $00      RESET COUNTERS
0049 85 51      STAZ  CNTONE
004B 85 52      STAZ  CNTTWO

004D 68          EXIT  PLA          RESTORE X REGISTER
004E AA          TAX
004F 68          PLA          RESTORE A REGISTER
0050 40          RTI          RETURN FROM INTERRUPT

0051 00          CNTONE =    $00      FRACTIONAL COUNTER
0052 00          CNTTWO =    $00      INTEGER COUNTER

```

registers, and then zeros the contents of the frequency counter locations. The interrupt program is exited by restoring the values of A and X and returning via the RTI instruction.

The Hardware Configuration

Figure 3 illustrates the additional logic required to use the KIM as a frequency counter and shows how that logic is connected to the KIM Expansion connector. The purpose of the 74121 monostable multivibrator is to produce a negative going pulse of short duration onto the IRQ interrupt lines whenever the input to that chip experiences a high-to-low transition. It should be noted that the IRQ is a level rather than an edge sensitive interrupt and that the interrupt line must be held low only long enough to allow the processor to sense the interrupt. Therefore, with the addition of this flip-flop the KIM will experience an IRQ interrupt each time the input source exhibits a high-to-low transition. If a periodic pulse train is being applied to the input, then an IRQ interrupt will be experienced on each cycle.

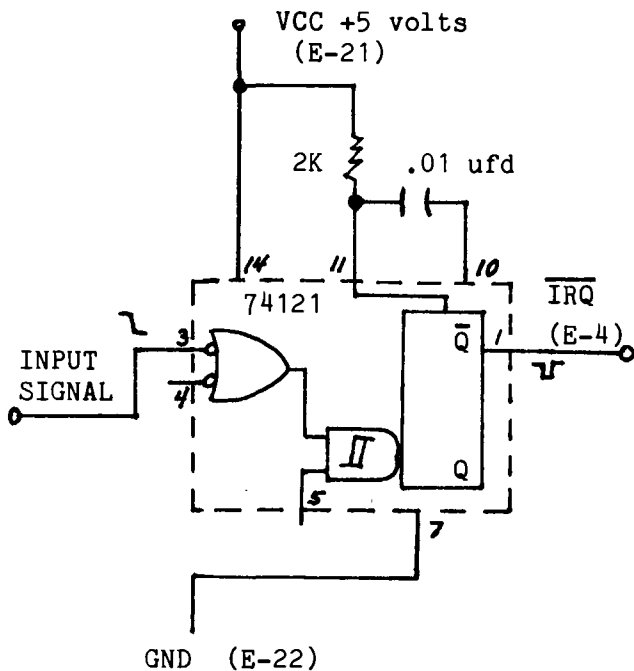

Figure 3

The accuracy of this hardware/software on a KIM-1 for measuring frequencies is shown in the table (Figure 4). A very accurate frequency meter was used to obtain the meter measurements. Since there are probably slight variations in the speed of different KIM-1s, you should calibrate your own unit before using it for any "real" measurements.

Frequency Calibration

Meter	KIM
14.960	15.00
13.961	14.00
12.960	13.00
11.968	12.00
10.966	11.00
9.965	10.00
8.970	9.00
7.977	8.00
6.984	7.00
5.983	6.00
4.985	5.00
3.992	4.00
2.991	3.00
2.003	2.00
1.003	1.00
.902	0.90
.801	0.80
.705	0.70
.608	0.60
.507	0.50

Figure 4

Additional Comments

In addition to entering the values shown in the accompanying listing, the values 0010 should be stored in locations 17FA and 17FB, and 2100 should be stored in locations 17FE and 17FF. The latter value directs program control to the beginning of the interrupt routine when an IRQ is sensed.

The results displayed on the seven segment indicators will be in the form XX.XX KHz. This format was chosen for convenience and the range can be shifted for higher accuracy by software modifications. Additional improvements are left to the reader to create. The author would appreciate being informed of any interesting improvements you come up with.

**6502 BIBLIOGRAPHY
PART II**

William Dial
438 Roslyn Avenue
Akron, OH 44320

129. Torzewski, Joe, "Apple I Library" On_Line 2 No. 12 p. 11 (Sept 14, 1977)
Apple I owners interested in a library for software and hardware should contact Joe Torzewski, 51625 Chestnut Rd., Granger IN 46530.
130. House, Gil, P.O. Box 158, Clarksburg, MO 20734, "6502 Tape Labeler" On_Line 2 No. 12 p. 11 (Sept 14, 1977)
Man readable 6502 legible tape labeler for TIM, JOLT, DEMON
131. Cater, J., 11620 Whisper Trail, San Antonio, TX 78230, "Run OSI 6502 8K BASIC on your Tim or Jolt" On_Line 2 No. 11, p. 13 (Sept 14, 1977)
Full info and patches to run this super fast BASIC.
132. Staff Article "The PET Computer" Personal Computing 1 No. 5, pp 30-40 (Sept-Oct, 1977)
Interviews with Chuck Peddle of Commodore and with other micro-computer experts.
133. Lancaster, Don, "Hex-to-ASCII Converter for your TVT-6" Popular Electronics 12 No. 4, pp 49-52 (Oct. 1977)
Simple module produces op-code display for entire computer. Describes a board to be connected between the TVT-6 and the KIM-1 microcomputer.
134. Microcomputer Associates Inc., 2368-C Walsh Ave., Santa Clara, CA 95050
Popular Electronics 12 No. 4, p. 100 (Oct, 1977)
New Product Announcement: A 6502 RAP, resident assembler program and TINY BASIC of ROM. Cost \$200.
135. CGRS Microtech, P.O. Box 368, Southampton PA 18966, On_Line 2 No. 13, p 2 (Oct 5, 1977)
New Product Announcement: EXOS and DATE are two new 6502 software packages. EXOS is an Extended Operating System featuring a number of useful commands and DATE is a disassembler, assembler, trace and debug editor. Available on four programmed 2708 EPROMS or on TIM format paper tape. Programs are each \$150 or \$295 for both, on EPROMS.
136. Pyramid Data Systems, 6 Terrace Ave., New Egypt, NJ 08533, On_Line 2 No 13, p 6 (Oct 5, 1977)
New Product Announcement: XIM is a 1K software package for KIM that adds 17 commands to the KIM Monitor, including a Breakpoint routine. Cas- sette and 45 page manual is \$12 ppd., paper tape is \$10.
137. K L Power Supplies, P.O. Box 86, Montgomeryville, PA 18936, On_Line 2, No. 13, p. 11 (Oct 5, 1977)
New Product Announcement: Model 512 Power Supply is for the KIM with enough capacity for an extra 8K and other accessories.
138. Matthews, K., "6502 Forum" Kilobaud No. 10, p 11, (Oct. 1977)
Mentions E.C.D. Micromind II based on the 6512 A (related to 6502).
139. Rugg, Tom and Feldman, Phil, "BASIC Timing Comparisons" Kilobaud No. 10 p. 20 (Oct, 1977)
Compares over 30 different hobby computer systems on seven different Benchmark programs in BASIC. Fastest was OSI 8K BASIC using 6502 in a Challenger running at 2 MHz. Actually a late entry which was still a little faster was the HeathKit H-11 with a special Extended Instruc- tion Set and a Floating Instruction Set which are to be offered as accessories for the H-11.

140. Overstreet, Jim, "Try Your KIM-1 on RTTY" 73 Magazine No. 205 pp 88-91 (Oct, 1977)
Has a Baudot Receive Program that takes the output from an FSK converter and runs a video terminal with the KIM board. A CW transmit program is also given in the article.
141. Schawlow, Arthur L., "Search Subroutine for the 6502 Disassembler", Interface Age 2 No. 1, p 146 (Oct, 1977)
A description, listing and sample run of an object code search subroutine for use with the 6502 Disassembler published in the September 1976 issue of Interface Age.
142. Simonton, John S., Jr., "What the Computer does ... an Introduction.", Polyphony 3, No. 1, pp 5-7, 28 (July, 1977)
PAIA Electronics will shortly have a complete KIM-1 package showing how to interface with their 8700 Computer Controller based on a 6503 processor. A large selection of programs for KIM is promised.
143. Simpson, Rick, "KIM Forum", Kilobaud No. 11, pp 16-17, 48 (Nov, 1977)
Caxton Foster of the Computer Sciences Dept. of the University of Massachusetts is the author of a college text on microprocessors and all programming examples use KIM-1. Also R.W. Burhans, E.E. Dept. of Ohio University has some informative comments on the adjustment of the PLL pot VR-1.
144. Butterfield, Jim, "Hyper about Slow Load Times", Kilobaud No 11, pp 66-69 (Nov, 1977)
Butterfield explains the development of his HYPERTAPE (Supertape) program for loading or dumping to a KIM audio cassette at 50 bytes per second, six times the normal KIM-1 rate.
145. Blankenship, John, "Expand Your KIM", Kilobaud No 11, pp 84-87 (Nov 1977)
The first of several articles on expanding KIM to use the S-100 bus to give 13K memory, Cromenco Dazzler, a printer and keyboard, joysticks, etc.
146. Johnson Computer, P.O. Box 523, Medina, OH 44256, On Line 2, No 14, p 7 (October 26, 1977)
New Product Announcement: KIM-1 8K Basic by Microsoft is available in either a 6-digit or 9-digit precision version which includes full printout of error messages. Prices are \$97.50 and \$129.00.
147. Rockwell International, P.O. Box 3669, Anaheim, CA 92803, Product Bulletin
Rockwell now has available a number of 6500 family microprocessor chips including r6502, r6505 and others. They also are promoting SYSTEM 65, a floppy disc based powerful development system.
148. Sneed, James R., "Adding an Interrupt Driven Real Time Clock", Byte 2 No. 11, pp 72-74 (Nov, 1977)
An external board drives interrupts at 15 Hz which is used to calculate time for use by the computer.
149. Brader, David, "A 6502 Personal System Design: KOMPUUTAR", Byte 2 No. 11 pp 94-137 (Nov, 1977)
A very detailed constructional article.
150. NCE/CompuMart, 1250 N. Main St., Ann Arbor, MI 48104, Byte 2 No. 11, p 140, (Nov, 1977)
New Product Announcement: A number of Accessories for the KIM-1 including backplane/S-100 adapter, 8K Seals memory, Poly Video terminal interface, Itty Bitty Tiny BASIC, Matrox Video RAMS, Graphics and Alpha-Numerics Boards.
151. The Enclosures Group, 55 Stevenson St., San Francisco, CA 94105, Byte 2 No. 11, p 234 (Nov, 1977)
New Product Announcement: Offers an enclosure to dress up the KIM-1.

152. Apple Computer Inc., 20863 Stevens Creek Blvd., Cupertino, CA 95014, Byte 2, No. 11, p 252 (Nov, 1977)
 Apple II is a new entry in the home computer market. At \$1298 it offers 6K Basic in ROM video graphics in 15 colors, 4K of programmable memory in RAM, a 2K monitor, cassette interface, floating point package, etc.
153. Anon., "Get the most out of Basic", OSI Small Systems Journal 1, No. 2, pp 4-7 (Sept, 1977)
 Note on Basic in general and the OS-65D System.
154. Smith, Gary A., "Contributed Program", OSI Small Systems Journal 1, No. 2, p. 12 (Sept, 1977)
 Program displays the memory address and the data contained in HEX.
155. Anon., "OSI 6502 Cycle Time Test", OSI Small Systems Journal 1, No. 2, pp 12-13 (Sept., 1977)
 Measures the cycle time using a stop watch and program to record the number of whole cycles.
156. Anon., "Memory Test", OSI Small Systems Journal 1, No. 2, pp15-17(Sept 1977)
 A memory test for video and serial-based computers using the 6502.
157. Anon., "1K Corner: Close the Window", OSI Small Systems Journal 1, No. 2, p 18 (Sept., 1977)
 Close the Window is a dice game designed to be played on the OSI 65V Computers.
158. The COMPUTERIST, P.O. Box 3, South Chelmsford, MA 01824
 MICRO is a new bimonthly publication specializing in information related to 6502 processor based systems.
159. Salzsieder, Byron, "Cheap Memory for the KIM-1", MICRO No. 1 pp 3-4, Oct.-Nov., 1977)
 You can add a Veras Systems 4K Byte memory board to your KIM-1 at half the price of the KIM-2.
160. Holt, Oliver, "Terminal Interface Monitor (TIM) for the 6502", MICRO No. 1, pp 1-7 (Oct.-Nov., 1977)
 TIM is available on a MOS Technology ROM 6530.
161. Anon., "We're No. 1", MICRO, No. 1, p 6 (Oct-Nov, 1977)
 An editorial points out that over 12,000 KIM-1 units are in the field and a thousand more each month are being ordered. Apple I and Apple II systems, plus the OSI units, Jolts, Data Handlers, and other 6502 based systems, plus the huge number of PETs and Microminds that have been ordered, plus a lot of home-brew systems, it all adds up to a lot of 6502 systems. Also Atari has purchased one and one-half million 650X chips for their game units.
162. Ferruzzi, Arthur, "Inside the Apple II", MICRO, No. 1, pp 9-10 (Oct-Nov 1977)
 A detailed description of the Apple II.
163. Ferruzzi, Arthur, "Rockwell International and the 6502", MICRO, No. 1, p 10, (Oct.-Nov., 1977)
 Rockwell is now second sourcing the entire 6502 product line. They have also developed SYSTEM 65, a fancy development system with dual mini floppies, 16K static RAM, text editor, assembler and debug monitor on ROM, serial and parallel interfaces for terminal and printer, hardware breakpoint, etc.
164. Floto, Charles, "The PET's IEEE-488 Bus: Blessing or Curse?", MICRO, No. 1, p 11 (Oct.-Nov, 1977)
 Discussion of this feature mentions a rumor that Pickles and Trout may offer a 488 adapter for their new S-100 I/O board, as well as an I/O board for the 488 bus.

165. Anon., "6502 Related Companies", MICRO, No. 1, p12 (Oct.-Nov., 1977)
Lists 28 companies serving 6502 processors.
166. Tripp, Robert M., "Hypertape and Ultratape", MICRO, No. 1, pp13-16,
(Oct.-Nov., 1977)
Ultratape runs at 12 times the normal KIM-1 speed, but requires special programs for both loading and dumping.
167. Rowe, Mike, "KIM-Based Degree Day Dispatcher", MICRO, No. 1, pp 17-18,
(Oct.-Nov., 1977)
Hundley Controls of Hanover, Mass. is building a number of different KIM-based systems to be used by fuel oil dealers to perform a variety of functions such as meter ticket reading, basic accounting, calculating degree-days by measuring temperature and determining when oil deliveries are to be made, etc.
168. Tripp, Robert M., "Computer Controlled Relays", MICRO, No. 1 p 19
(Oct.-Nov., 1977)
Relays can be used for control of audio assettes, and a variety of other functions. A 7404 Hex Inverter is used to buffer the signals from the KIM's 6530 Port B I/O lines.
169. Dial, William R., "6502 Bibliography", MICRO, No. 1, pp 21-27, (Oct. -
Nov., 1977)
128 references to 6502 related articles, programs, etc.
170. Camus, Armand L., "Making Music with the KIM-1", MICRO, No. 2, pp 3-7,
(Dec. 1977-Jan. 1978)
How to write music for a DAC such as that recently described by Chamberlain in Byte Magazine, Sept. 1977.
171. Floto, Charles, "Meet the PET", MICRO, No. 2, pp 9-10 (Dec 1977-Jan 1978)
An owners view of the PET 2001.
172. Dejong, Marvin L., "Digital-Analog and Analog-Digital Conversion Using
the KIM-1", MICRO, No 2, pp 11-15, (Dec. 1977-Jan 1978)
Experiments with a KIM-1 controlled DAC/ADC.
173. Wallace, Bob, "The PET Vs. the TRS-80", MICRO No. 2, pp 17-18,
(Dec. 1977 - Jan 1978)
A feature-by-feature comparison.
174. Schwartz, Marc, "Ludwig von Apple II", MICRO, No. 2, p 19 (Dec 77-Jan 78).
How to write music for the Apple II.
175. Anon., "MICROBES - Tiny Bugs in Previous MICRO", MICRO, No. 2, p 22,
(Dec. 1977 - Jan. 1978).
Some corrections for HYPERTAPE and ULTRATAPE and Computer Controlled Relays.
176. Henkel, Joel, "The Challenge of the OSI Challenger", MICRO, No. 2,
pp 23-24 (Dec 1977 - Jan 1978)
An owners impressions of the OSI Challenger.
177. MOS Technology, "Improving Keyboard Reliability", MICRO, No. 2, p 25,
(Dec 1977 - Jan 1978)
A hardware modification for your KIM-1 to improve action of the "9, D,
or C" keys. Based on an Application Note by MOS Technology.
178. Dial, William, "Important Addresses of KIM-1 and Monitor", MICRO, No. 2,
pp 27-30, (Dec 1977 - Jan 1978)
A programmers reference card for the KIM-1.
179. Computer Shop, 288 Norfolk St., Cambridge, MA 02139, MICRO, No. 2,
p 26, (Dec. 1977 - Jan. 1978)
Advertisement for CS 100 Video Terminal Board for KIM. Includes portable cabinet for the KIM with space for cassette recorder, ASCII keyboard, power supply, extra memory boards, 3-slot motherboard, TIM kit, etc.

Three PLUSes for the KIM-1:

MEMORY PLUS™

8K RAM

5V REGS.

up to 8K
EPROM

2K EPROMs

\$50 each

6522 I/O

EPROM
PROGRAMMER

\$245⁰⁰

Assembled

Low Power RAM

All ICs Socketted

Intel 2716 EPROMs

Mounts Below KIM-1

ENCLOSURE PLUS™

\$30⁰⁰

Made by "The Enclosures Group" especially for the KIM-1/MEMORY PLUS combination. The MEMORY PLUS is mounted directly below the KIM-1 providing a compact package about 2.5" high which affords your system a high degree of protection from damage, dust, curious fingers, etc.

POWER PLUS™

\$40⁰⁰

Designed specifically for the KIM-1. It has regulated +5V and +12V for the KIM-1 and more than enough unregulated +8V to power the MEMORY PLUS. It is completely enclosed in a black bakelite case measuring about 6.8" by 5.6" by 3". It is fully assembled and tested and weighs about 3 lbs.

MEMORY PLUS is \$245 with everything except EPROMs.
KIM-1/MEMORY PLUS Cables are \$10.00
Includes 60 page manual, cassette tape, connectors.

The COMPUTERIST
P.O. Box 3
S Chelmsford, MA 01824
617/256-3649

LIGHTING THE KIM-1 DISPLAY

Marvin L. De Jong
The School of the Ozarks
Point Lookout, MO 65726

To light the display, ports A and B data direction registers (SADD and SBDD) must be loaded so that pins SA0-6 and SB1-4 are output pins.

Put \$7F in SADD at location 1741
Put \$1E in SBDD at location 1743

Numbering the digits on the display from left to right, Table 1 indicates the number to load to light the segment in each digit.

SBD (1742)	Digit Enabled
08	1
0A	2
0C	3
0E	4
10	5
12	6

Table 1

Lettering the segments within the digit as shown in Figure 1, Table 2 indicates the number to load into SAD to select each segment.

To display any character, add the hex numbers in Table 2 which correspond to the segments to be lighted, then add 80. This latter step insures that pin PA7 remains high. Table 3 shows the values required for the sixteen Hex digits.

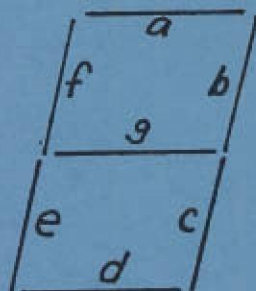

Figure 1

SAD (1740)	Segment Lit
01	a
02	b
04	c
08	d
10	e
20	f
40	g

Table 2

A table with these hex numbers is located in ROM on the KIM-1. It starts at 1FE7 and ends at 1FF6. To access the table, use LDAX TABLE, where TABLE is 1FE7 and X is the number to be displayed, then STA SAD, making sure that the appropriate digit is enabled.

SAD (1740)	Character
BF	0
86	1
DB	2
CF	3
E6	4
ED	5
FD	6
87	7
FF	8
EF	9
F7	A
FC	B
B9	C
DE	D
F9	E
F1	F

Table 3

Table 4 is a character generator for the alphabet and a couple of other characters. Note that some characters simply can not be made with the seven segment display.

Char	Upper	Lower	Char	Upper	Lower
A	F7		O	BF	DC
B		FC	P	F3	
C	B9	D8	Q		E7
D		DE	R		DO
E	F9		S	ED	
F	F1		T		F8
G	BD	EF	U	BE	9C
H	F6	F4	V		
I	B0		W		
J	9E		X		
K			Y	EE	
L	B8	86	Z	DB	
M			?	D3	
N	B7	D4	-	CO	

Table 4